



Marine & Offshore
Fire Divisions

bulkhead, deck
and floor systems

ABOUT MORGAN ADVANCED MATERIALS



Morgan Advanced Materials is a global engineering company offering world-leading competencies in materials science, specialist manufacturing and applications engineering.

We focus our resources on the delivery of products that help our customers to solve technically challenging Problems, enabling them to address global trends such as energy demand, advances in healthcare and environmental sustainability.

What differentiates us?

Advanced material science and processing capabilities. Extensive applications engineering experience. A strong history of innovation and reinvention. Consistent and reliable performance. A truly global footprint. We find and invest in the best people.

Contents

Introduction	4	Jet Fire Systems	63
A60 steel decks and bulkheads	7	Jet Fire Division JF/120/30 and JF/180/120	64-65
A60 steel deck	10	Jet Fire Division JF/125/30 and JF/180/60	66
A60 steel bulkhead - single layer	11	System summary tables	67
A60 steel bulkhead - double layer	12	Steel bulkheads	68
A60 steel bulkhead - alternative installation options	13	Steel decks	69
A60 floating floor	14	B15 wall extension	70
A60 corrugated steel bulkhead	15	Aluminium bulkheads & decks : A-Class	71
A60 corrugated steel bulkhead - 1.5mm steel thickness	18	Aluminium bulkheads & decks : HSC Code	72
A60 corrugated steel bulkhead - 4.5mm steel thickness	19	Composite divisions bulkheads & decks : HSC Code	73
B15 wall extension system	21	H-Class bulkheads & decks	74
B15 wall extension system	22-23	Jet Fire (JF) Class Fire Divisions	75
B15 wall extension system - detail drawings	24-26	Corrugated plate bulkheads	75
SOLAS - 'Safe Return to Port' regulations	27	System features	77
Lightweight fire insulation for fire protection of steel pipes	28-29	Anchoring	78
A60 aluminium deck & bulkhead	31	Flexible blanket profile wrap	79
A60 aluminium deck	34	Large beam insulation options	80
A60 aluminium bulkhead	35-36	Taped joints	81
Loadbearing aluminium divisions for high speed craft (HSC)	37	Insulation to avoid heat bridging	82-85
Loadbearing aluminium divisions - deck	40	Stiffeners	86-88
Loadbearing aluminium divisions - bulkhead	41	Large beams	89-90
Bi-metallic anchor system for aluminium decks and bulkheads	42	Penetration sealing	91
Loadbearing FRP composite divisions for high speed craft (HSC)	43	Thermal insulation of bulkheads and decks	93-95
Loadbearing FRP composite divisions - deck	46	Acoustic insulation of bulkheads and decks	97
Loadbearing FRP composite divisions - bulkhead	47	Sound absorption	98-99
Anchor system for FRP composite divisions - decks and bulkheads	48	Sound reduction	100
Blast resistance of FireMaster® fire divisions	49	Guide to specification & certification of fire divisions used in marine & offshore	101
Stainless steel mesh covering	52	Requirements and classification of fire divisions	102-104
Glass cloth covering	53	Special considerations for fire divisions	105-109
H60 & H120 steel decks and bulkheads	55	Morgan Advanced Materials Fire Protection product range	111-112
H60 steel deck	58		
H60 steel bulkhead	59		
H120 steel deck	60		
H120 steel bulkhead	61		
H60 / H120 corrugated steel fire wall	62		

Introduction

This manual contains details of Morgan Advanced Materials fire insulation systems for the fire protection of bulkheads and decks in the marine and offshore construction industries.

For more than 30 years, FireMaster® insulation materials have provided lightweight fire insulation for structures exposed to both cellulosic and hydrocarbon fires in cruise ships, super-yachts, high-speed ferries, coastal defence vessels, offshore platforms and FPSO's. This manual presents our new improved systems based on our innovative FireMaster® Marine Plus blanket.

The highlights of these new systems are:

- **Lower weight designs that minimise weight contribution to structures**
- **Improved, simpler installation techniques leading to easier installation**
- **Combined fire, thermal and acoustic insulation**



FIREMASTER®

Complete system details and Type Approval certification can be obtained from our web site www.morganthermalceramics.com/firemaster or USB Systems Manual (available on request).

FireMaster Marine Plus blanket

- Insulation fibre with low biopersistence in density range 48 to 128kg/m³
- Non-Carcinogenic classification under EU regulations
- Non-Toxic to UK Defence Standard 02-713
- 1200°C fibre, suitable for cellulosic and hydrocarbon fire protection
- No chemical binder - no formaldehyde emission
- 25% to 50% weight reduction compared to standard mineral wool and similar products
- Blast Resistance up to 1.25 bar
- Less weight or thickness than mineral wool
- Lower thickness
- Good thermal insulation for HVAC requirements
- Good acoustic insulation
- DNV approved constructions
 - Steel
 - Aluminium
 - FRP

For more than 30 years, FireMaster® insulation materials have provided lightweight fire insulation for structures exposed to both cellulosic and hydrocarbon fires in cruise ships, super-yachts, high speed ferries, coastal defence vessels, offshore platforms and FPSO's.





FIREMASTER®



A60 steel decks and bulkheads

A60 steel decks and bulkheads

Low weight, easy installation and density as low as 48kg/m³ ensures suitability for vessels where the weight of construction materials is critical.

FIREMASTER®



Horizontally or vertically installed over the structure with fixing anchors at a uniform spacing of up to 350mm and with blanket joint placement allowed at any point along the structure.

- Lightweight and easy to install
- Easy to engineer and modify on site, requiring minimal site surveying
- Cost-effective

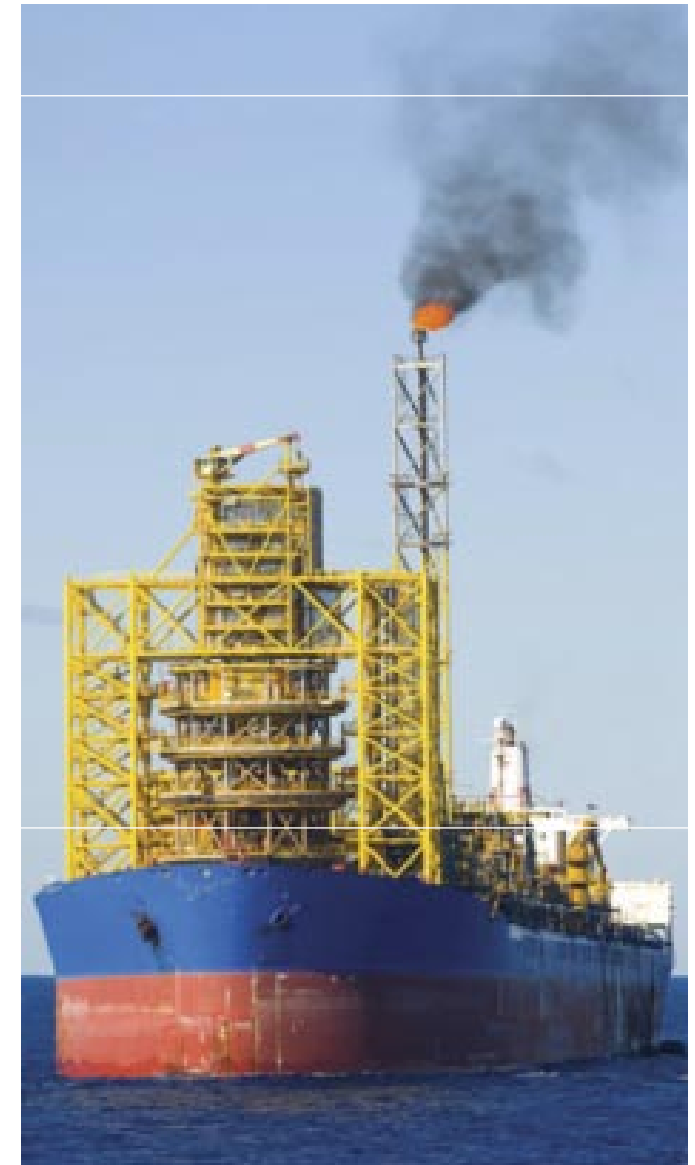

A60 steel deck

Single layer profile wrap system

48 density system - see table on page 69 for details of alternative multi-layer system

Ref.	Product	Thickness (mm)	Weight (kg/m ²)
a	FireMaster Marine Plus blanket 48kg/m ³ .	50	2.4
b	Stiffener - FireMaster Marine Plus blanket 48kg/m ³ .	50	2.4

64 density system

Ref.	Product	Thickness (mm)	Weight (kg/m ²)
a	FireMaster Marine Plus blanket 64kg/m ³ .	45	2.88
b	Stiffener - FireMaster Marine Plus blanket 64kg/m ³ .	45	2.88

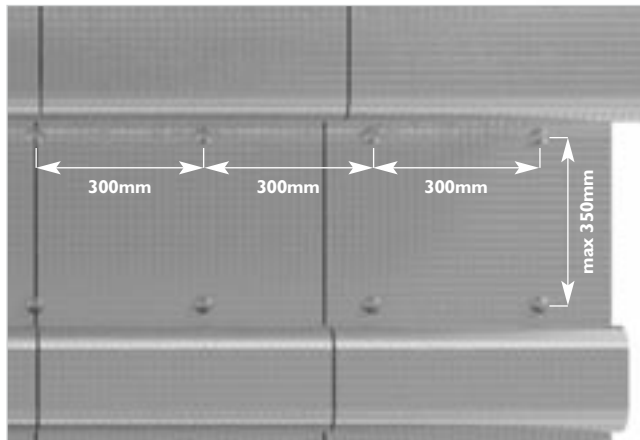

Uniform deck anchor pattern

Anchors are spaced at 300mm centres
 Joints between blankets can be up to 150mm from anchors
 Average anchors per m² = 9.5
 NB: All illustrations shown with un-taped joints

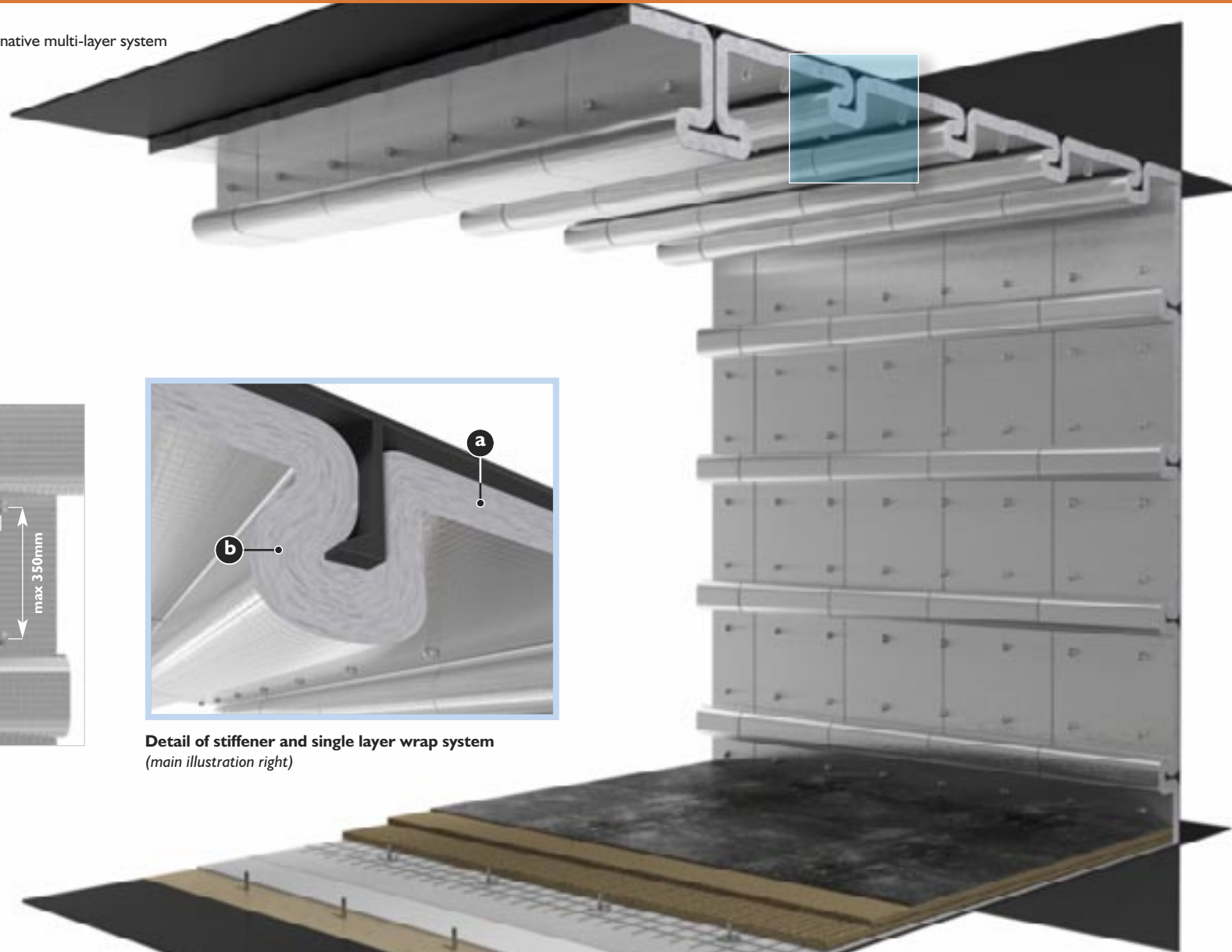

Detail of stiffener and single layer wrap system
 (main illustration right)

A60 steel bulkhead

Fire towards either side

Single layer profile wrap system

80 density system

Ref.	Product	Thickness (mm)	Weight (kg/m ²)
a	FireMaster Marine Plus blanket 80kg/m ³ .	60	4.8
b	Stiffener - FireMaster Marine Plus blanket 80kg/m ³ .	60	4.8

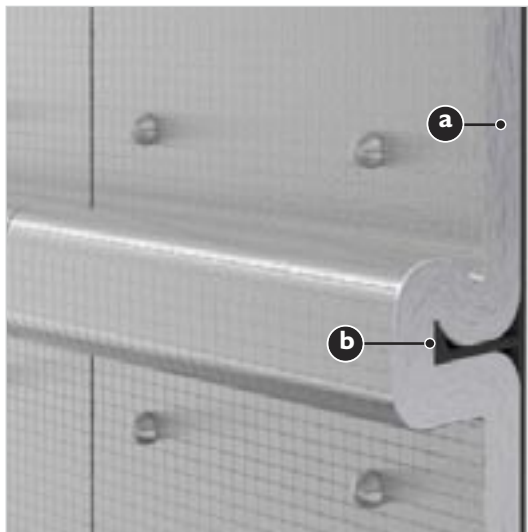

Detail of stiffener and single layer wrap system

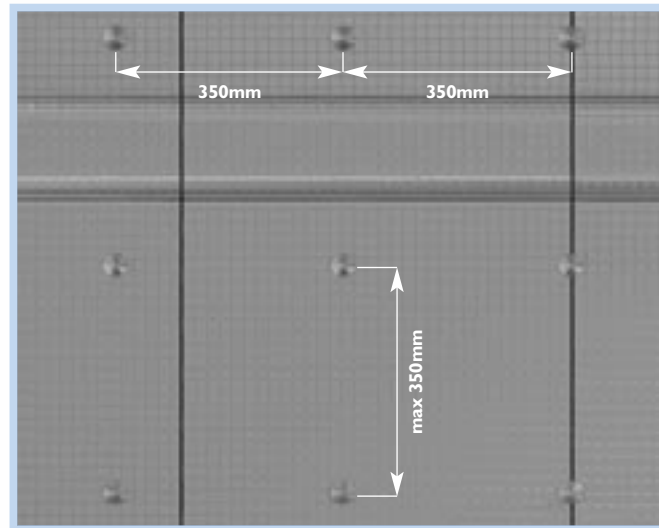

Detail of uniform bulkhead anchor pattern (main illustration right)

Anchors are spaced at 350mm centres

Joints between blankets can be positioned at any convenient location

Average anchors per m² = 8.1

NB: All illustrations shown with un-taped joints

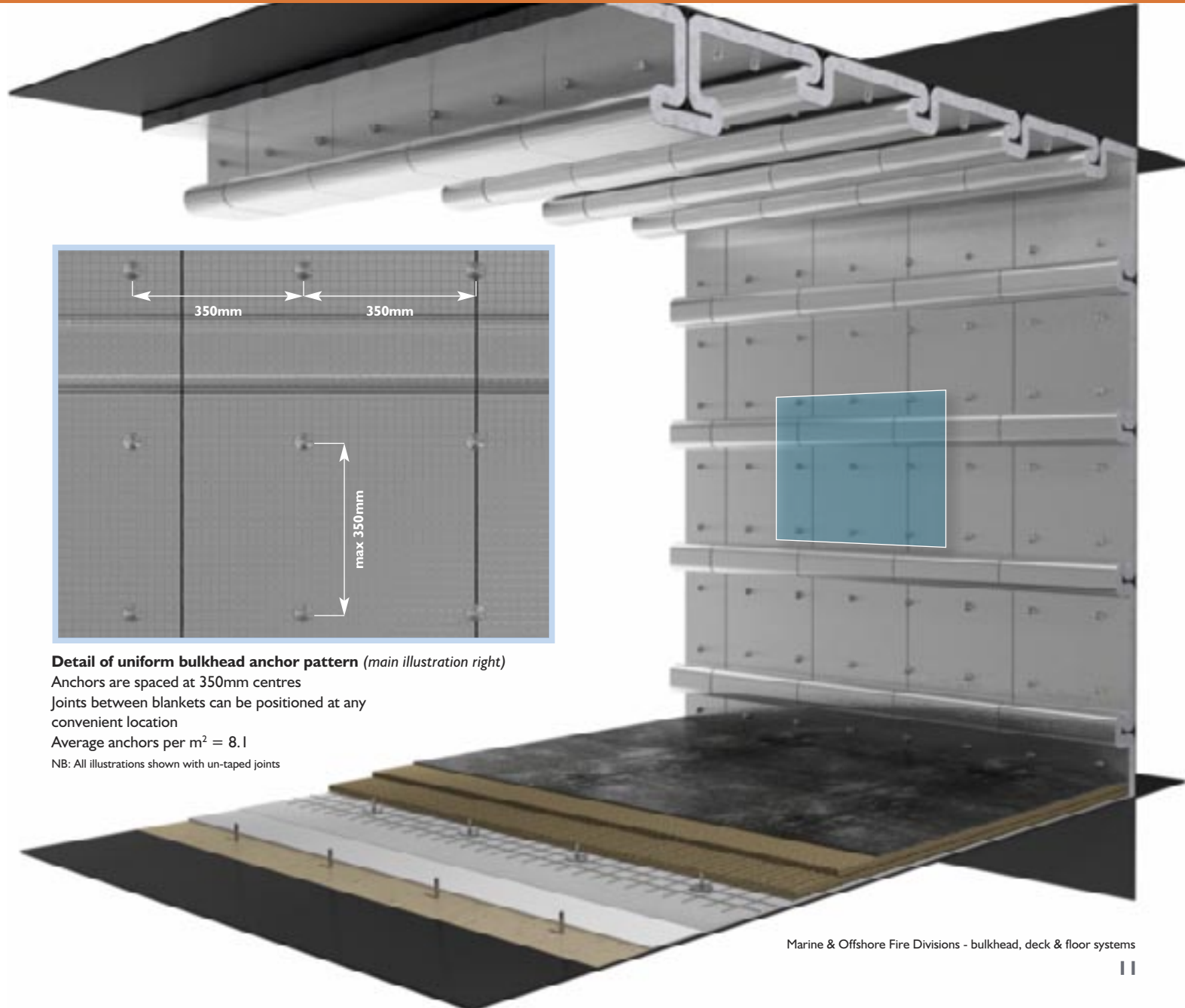

A60 steel bulkhead

Fire towards either side

Double layer profile wrap system

48 density system

Ref.	Product	Thickness (mm)	Weight (kg/m ²)
a	FireMaster Marine Plus blanket 48kg/m ³ .	40	1.92
b	Stiffener - FireMaster Marine Plus blanket 48kg/m ³ .	40	1.92

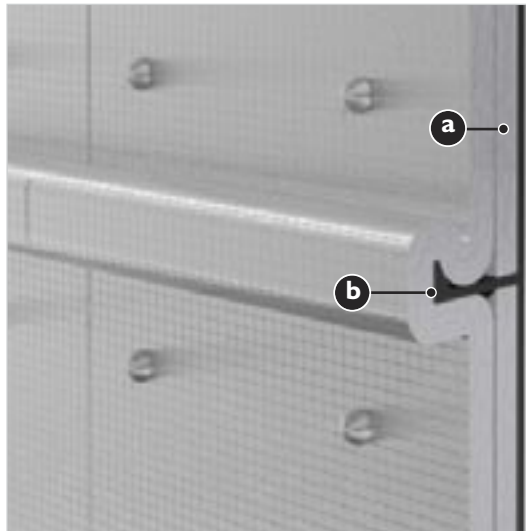

Detail of stiffener and double layer wrap system

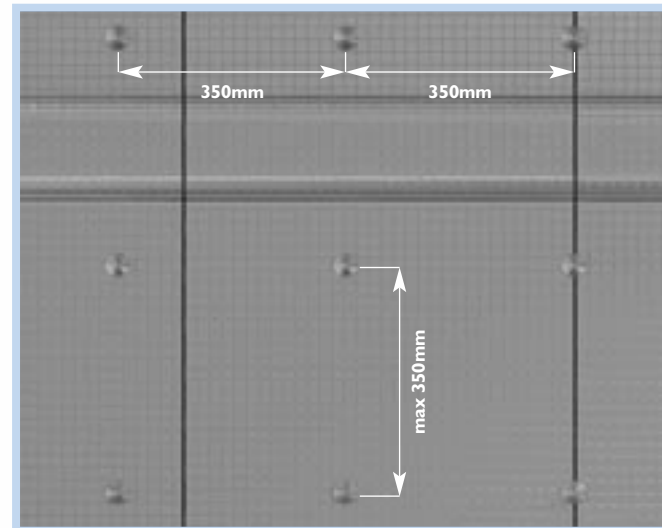

Detail of uniform bulkhead anchor pattern (main illustration right)

Anchors are spaced at 350mm centres

Joints between blankets can be positioned at any convenient location

Average anchors per m² = 8.1

NB: All illustrations shown with un-taped joints

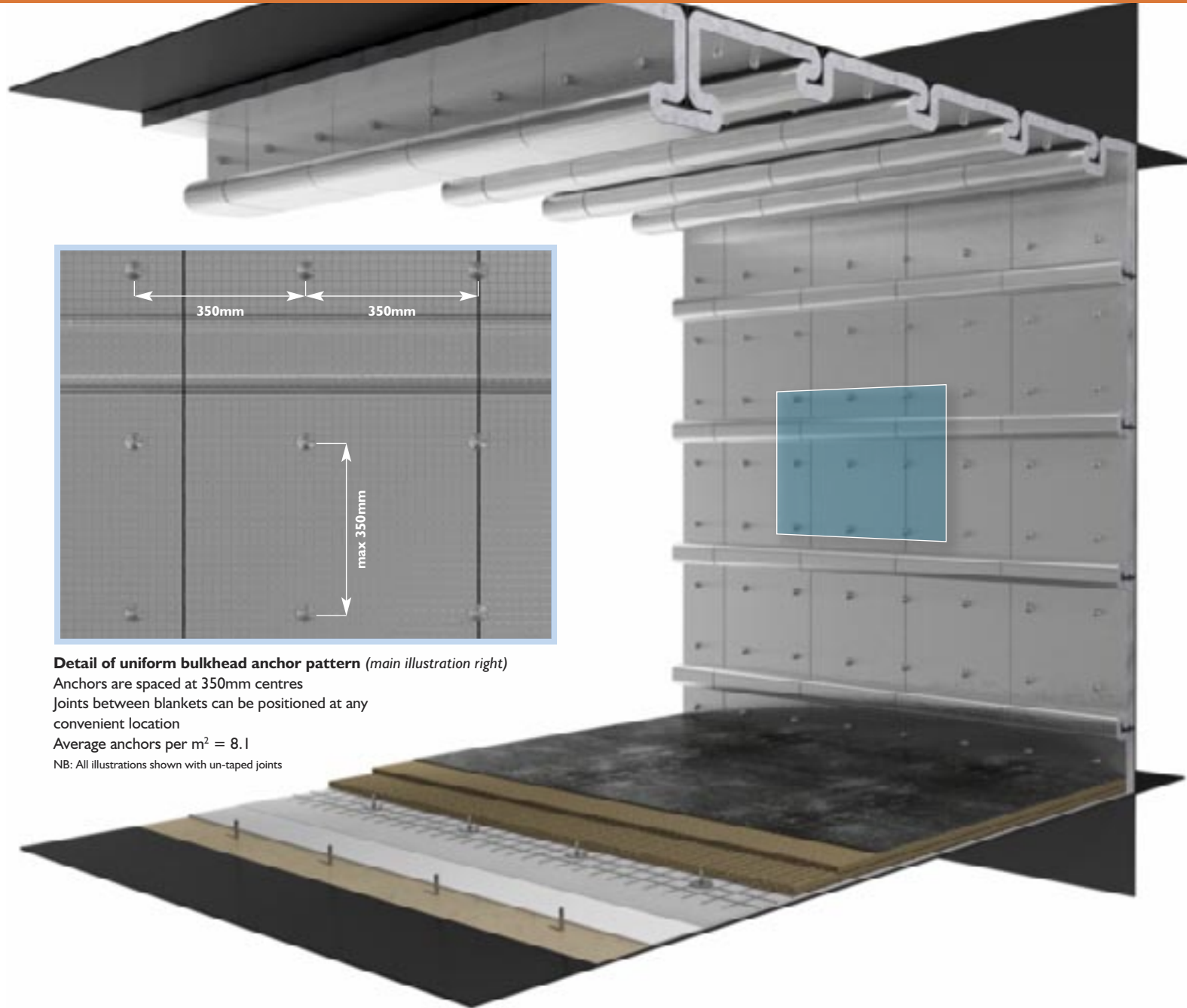

A60 steel bulkhead

Fire towards either side - 75mm x 64kg/m³ FireMaster Marine Plus blanket
Alternative installation options

64 density system

Ref.	Product	Thickness (mm)	Weight (kg/m ²)
a	FireMaster Marine Plus blanket 64kg/m ³ .	25	1.6
b	FireMaster Marine Plus blanket 64kg/m ³ .	30	4.8
c	FireMaster Marine Plus blanket 64kg/m ³ .	45	4.8
d	FireMaster Marine Plus blanket 64kg/m ³ .	50	4.8

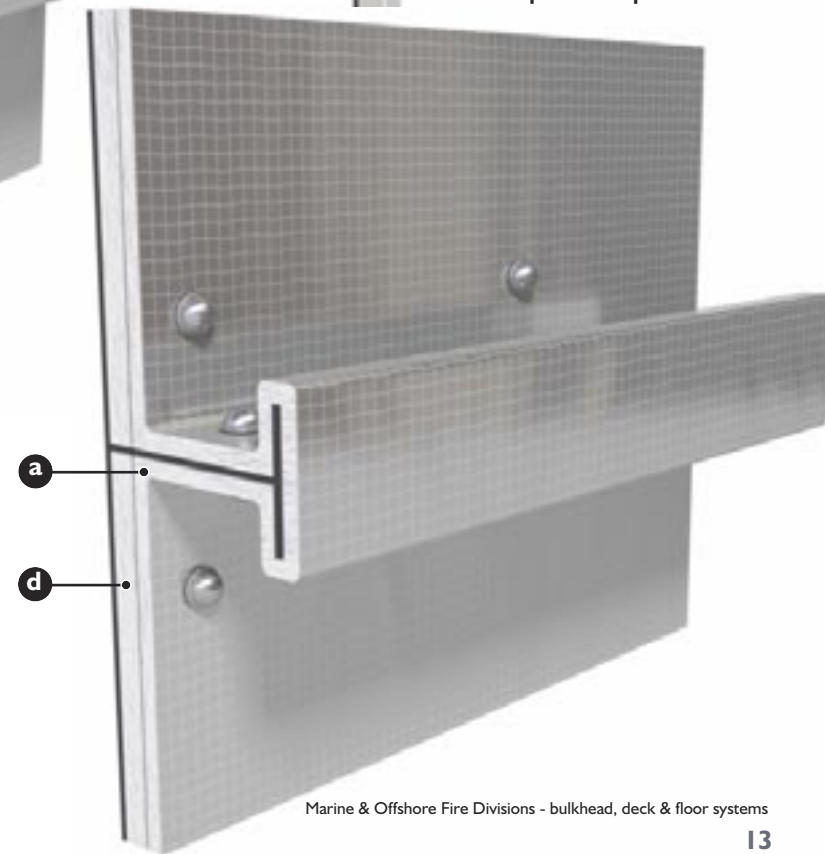
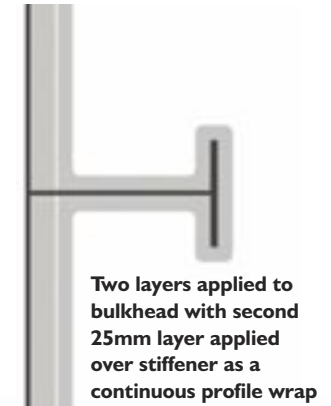
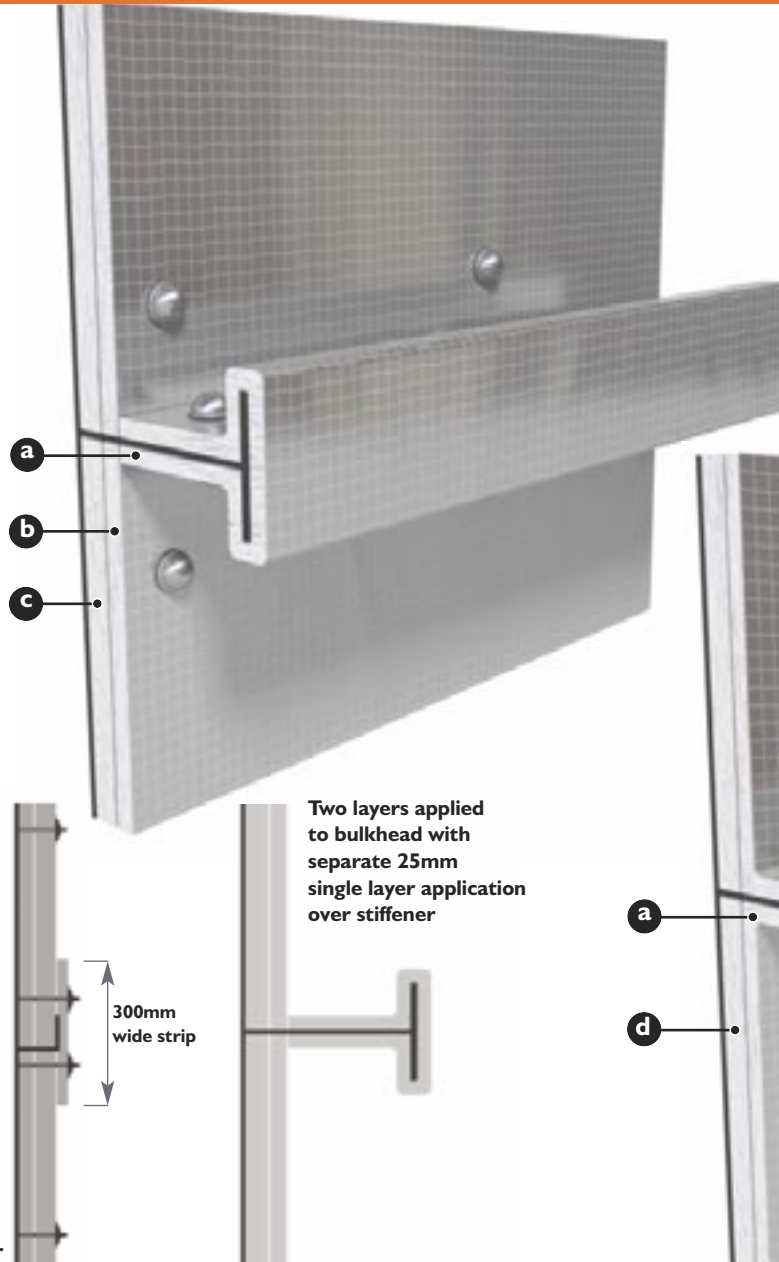
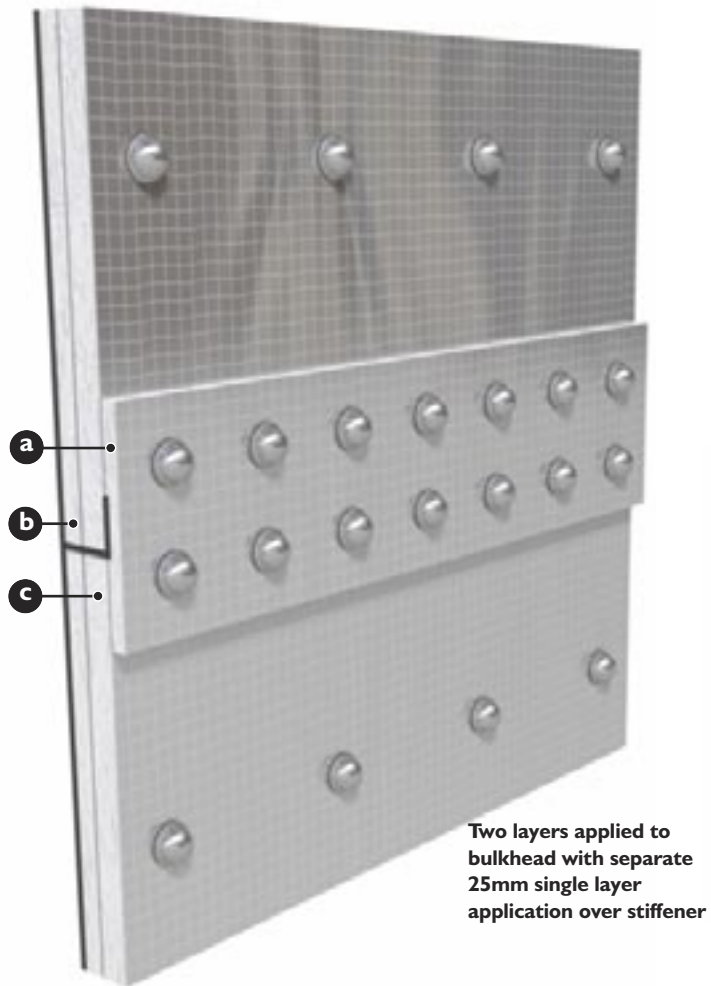

A60 floating floor

Typical flooring system

Ref.	Product
a	Steel deck.
b	Anchor pins.
c	Adhesive / Primer.
d	FireMaster paper.
e	Glass fibre fabric.

Ref.	Product
f	Steel net.
g	FireBarrier 135 : 20mm.
h	Fibre glass net.
i	Floor finish.

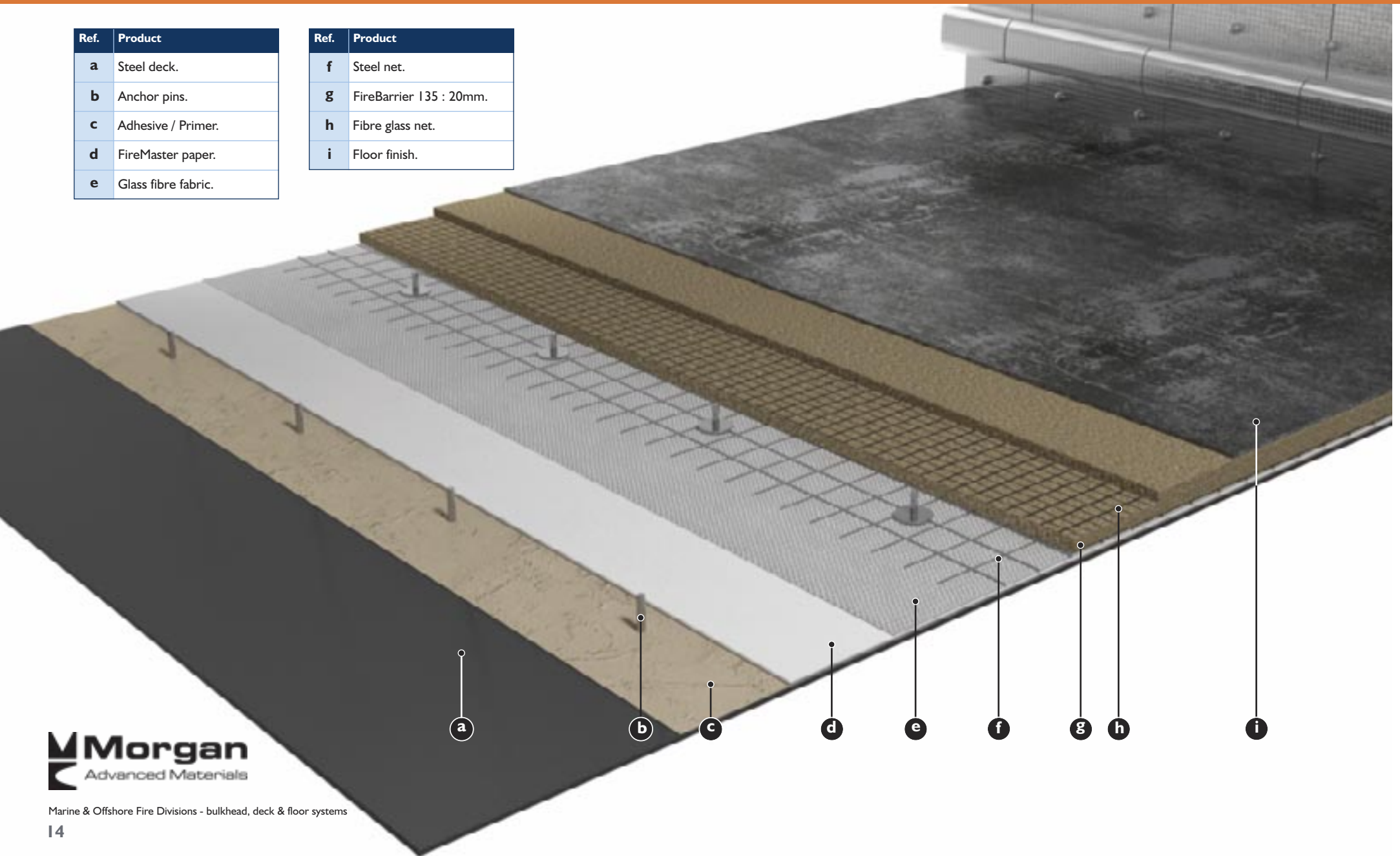



A60 corrugated steel bulkhead

1.5mm & 4.5mm steel thickness

A60 corrugated steel bulkhead

FireMaster® Marine Plus blanket is applied onto corrugated wall structures in a similar way as used for flat steel bulkheads. Precise layout varies with the steel wall thickness.

FIREMASTER®



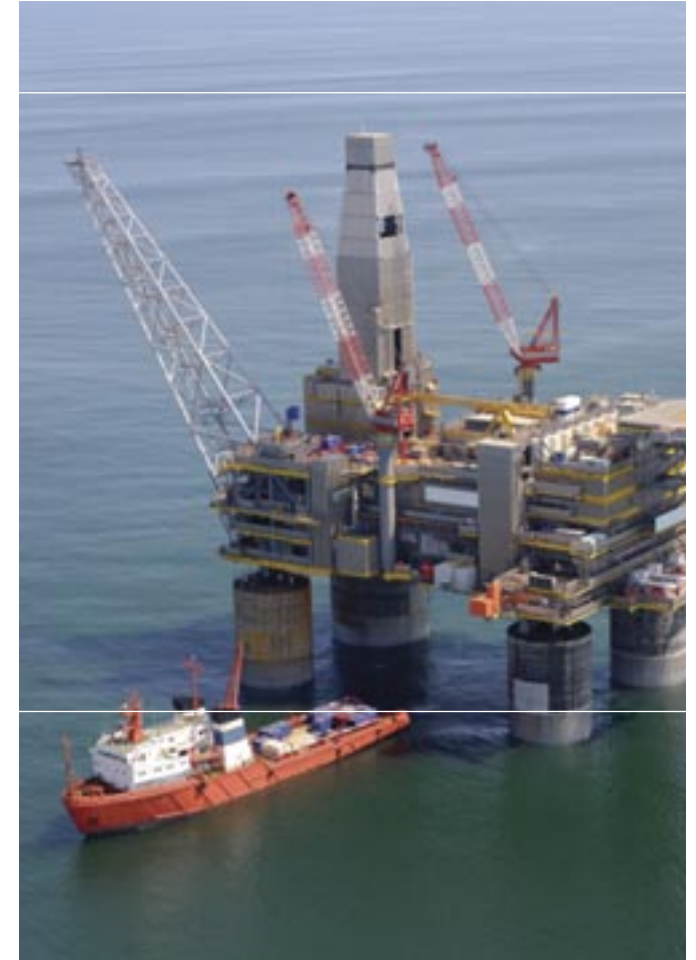

A60 corrugated steel bulkhead

Fire towards either side

1.5mm steel thickness

48 density system

Ref.	Product	Thickness (mm)	Weight (kg/m ²)
a	FireMaster Marine Plus blanket 48kg/m ³ .	50	2.4
b	FireMaster Marine Plus blanket 48kg/m ³ .	50	2.4
c	Stainless steel or mild steel corrugated plate.	1.5	-

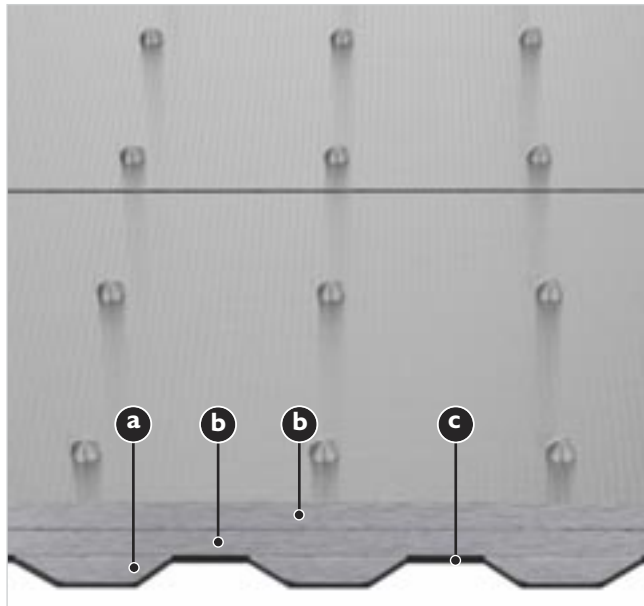

Detail of double layer wrap system over infilled corrugated sections

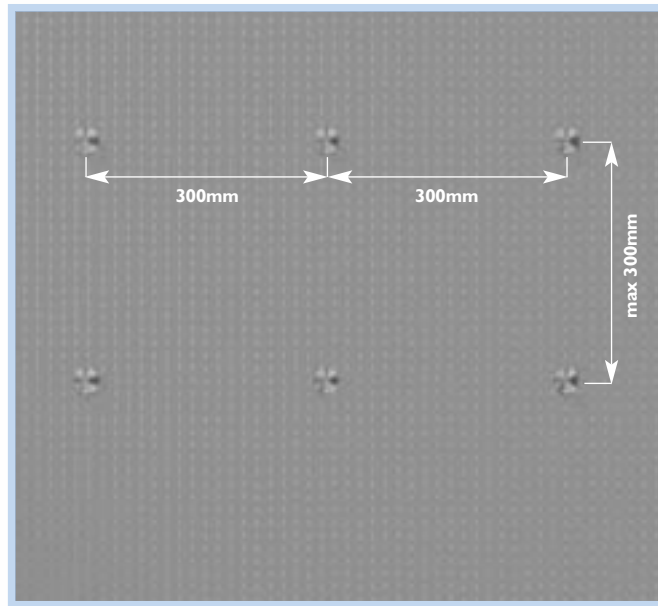

Detail of uniform bulkhead anchor pattern

(main illustration right)

Anchors placed in centre of each corrugation approximately 260mm to 300mm apart.

NB: All illustrations shown with un-taped joints

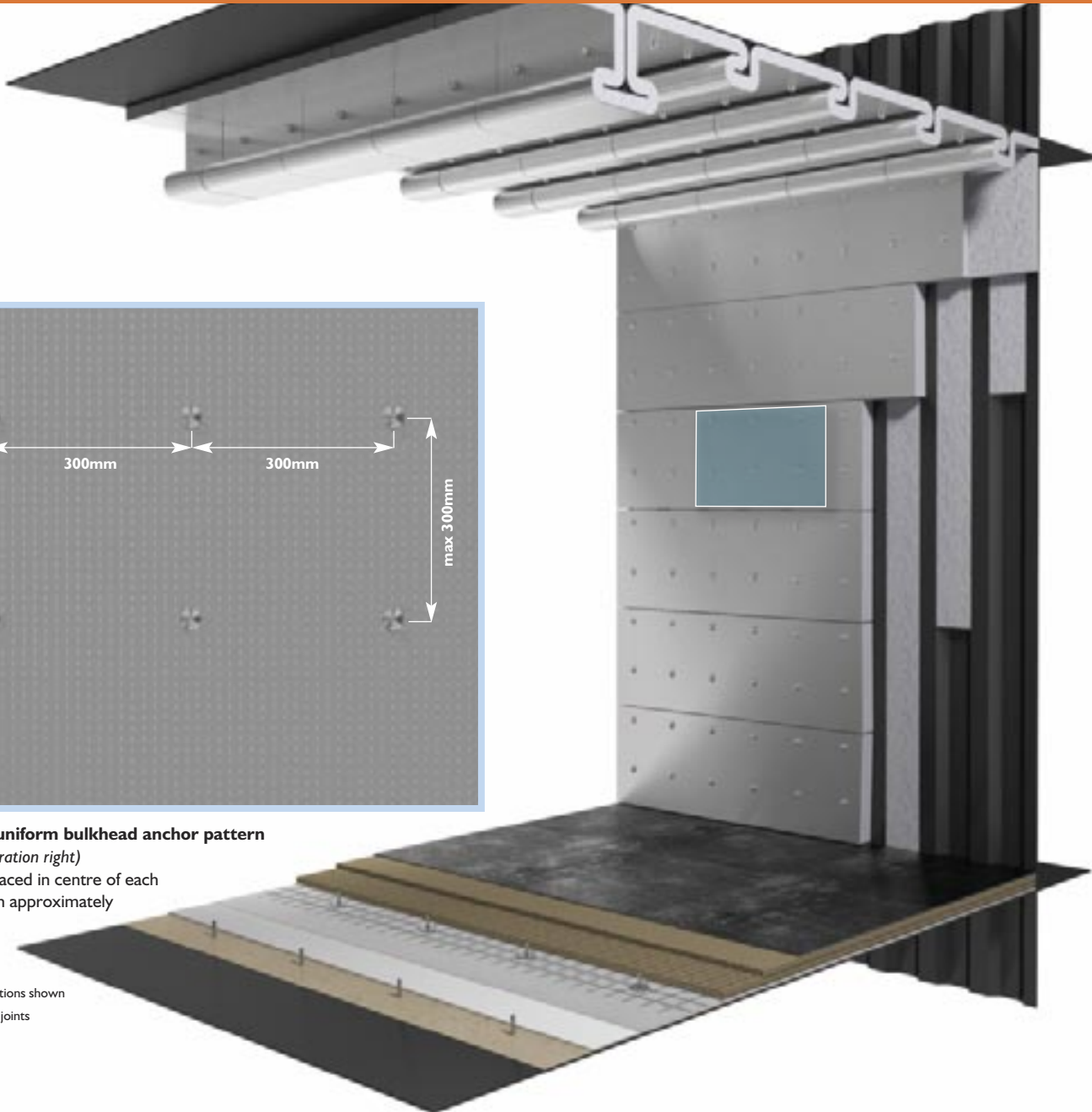

A60 corrugated steel bulkhead

Fire towards either side

4.5mm steel thickness

80 density system

Ref.	Product	Thickness (mm)	Weight (kg/m ²)
a	FireMaster Marine Plus blanket 80kg/m ³ .	60	4.8
b	Stainless steel or mild steel corrugated plate.	4.5	-



Detail of single layer wrap system

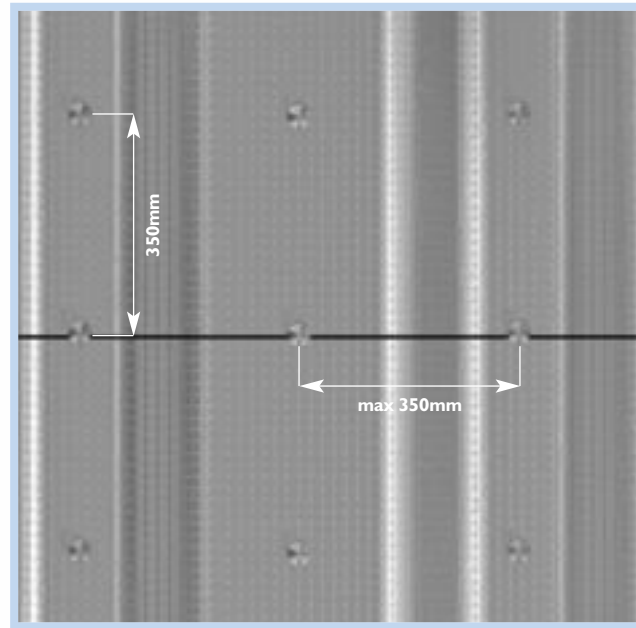

Detail of uniform bulkhead anchor pattern (main illustration right)

Anchors spaced at maximum of 350mm

centres to suit corrugation design.

Joints between blankets can

be positioned

at any convenient

location.

NB: All illustrations shown with un-taped joints

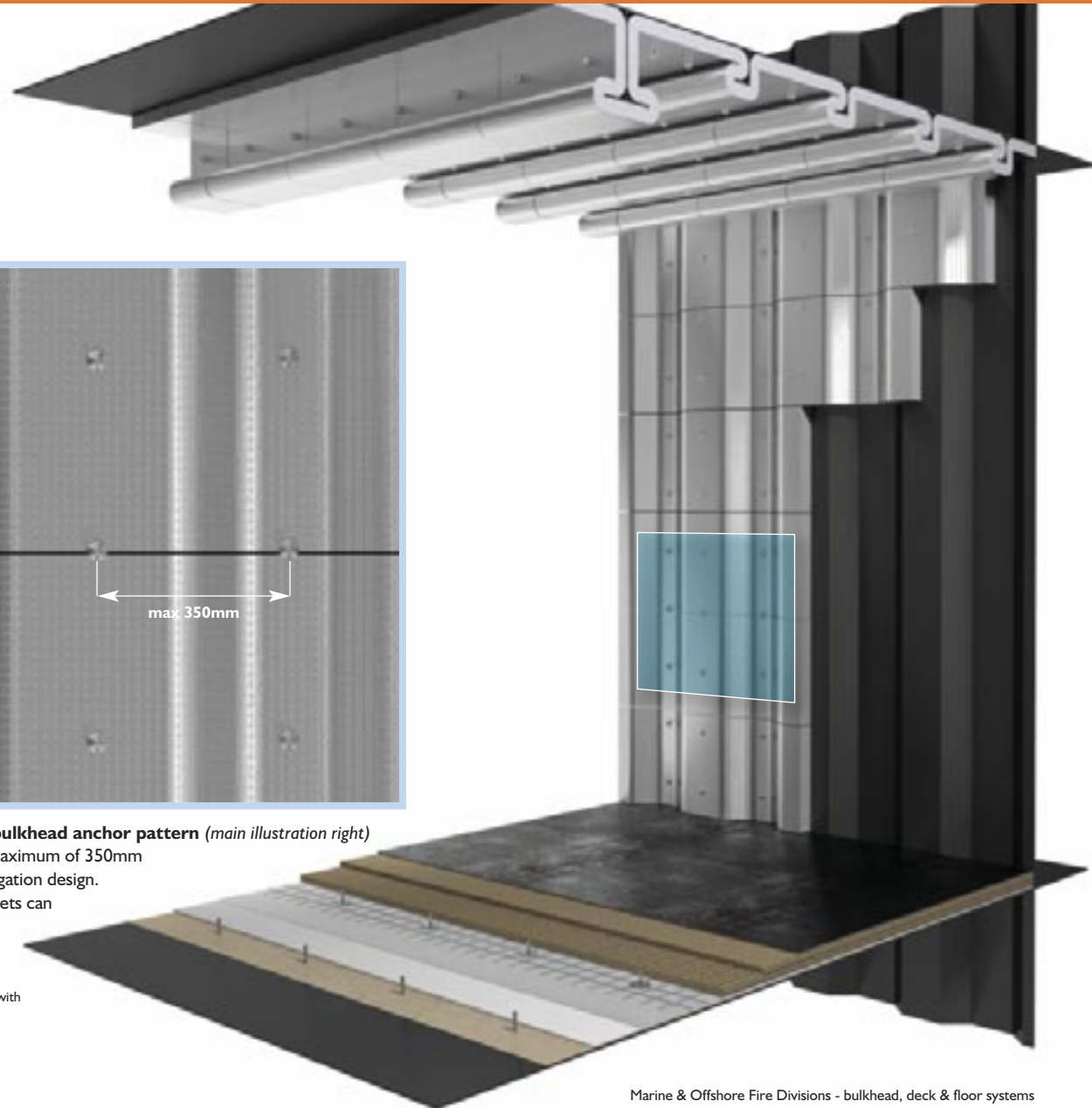



FIREMASTER®



BI5 wall extension system

B15 wall extension system

System features:

- Low weight of 2.4kg/m² is much lighter than alternative systems.
- Ease of installation : no steel bars required to fix the curtain elements together, no self adhesive alu-tape.
- Flexible system which is used as a curtain when cable tray and ventilation duct or water pipes are already installed.
- Installation of virtually all of the system is possible from the non-cabin side of the division where there is better access for installers to work.



B15 wall extension system

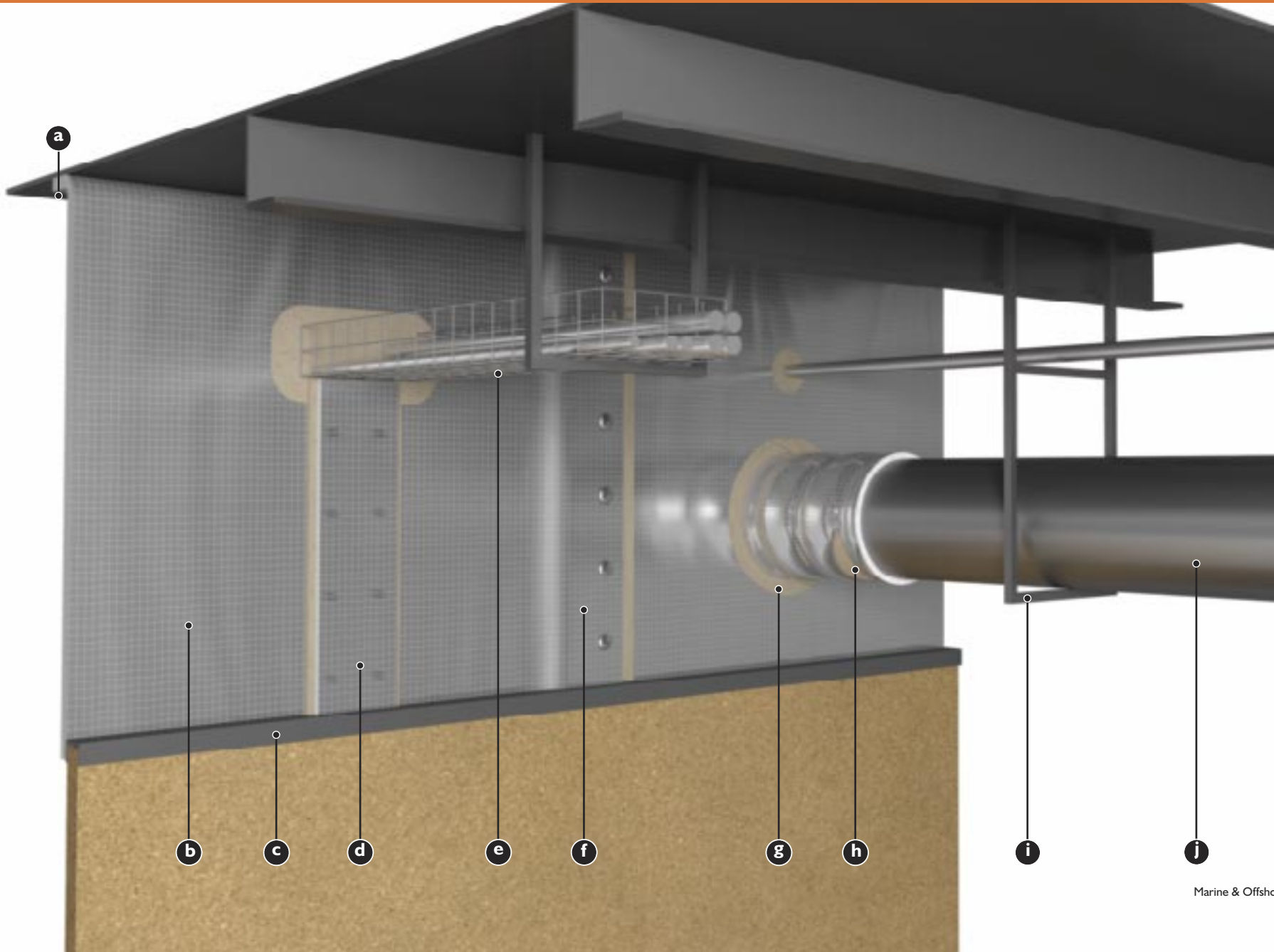

Ref.	Product
a	Anchor pins to fix B15 curtain to deck See detail drawing - page 26.
b	FireMaster Marine Plus blanket 30mm x 80kg/m ³ in rolls of 1220mm width with foil facing on both sides.
c	Steel U Channel.
d	150mm wide strip of FireMaster Marine Plus blanket 30mm x 80kg/m ³ with foil facing on both sides.
e	Cable tray with electrical cables mounted inside.
f	100mm overlap on edge of adjacent widths of FireMaster Marine Plus blanket.
g	Sealing mastic. Either FireMaster Putty or Isoflam 100 or Isoflam 105.
h	FireMaster Marine Plus blanket 30mm x 80kg/m ³ applied onto penetrating pipes for a distance of 100mm on each side of the B15 curtain where pipe external diameter exceeds 100mm. The blanket is fixed to the pipe by steel tie wire.
i	Mounting bracket for plastic pipe penetrating the curtain.
j	Plastic pipe.

B15 wall extension system

Detail views

Overlap arrangement of adjacent pieces of FireMaster Marine Plus blanket

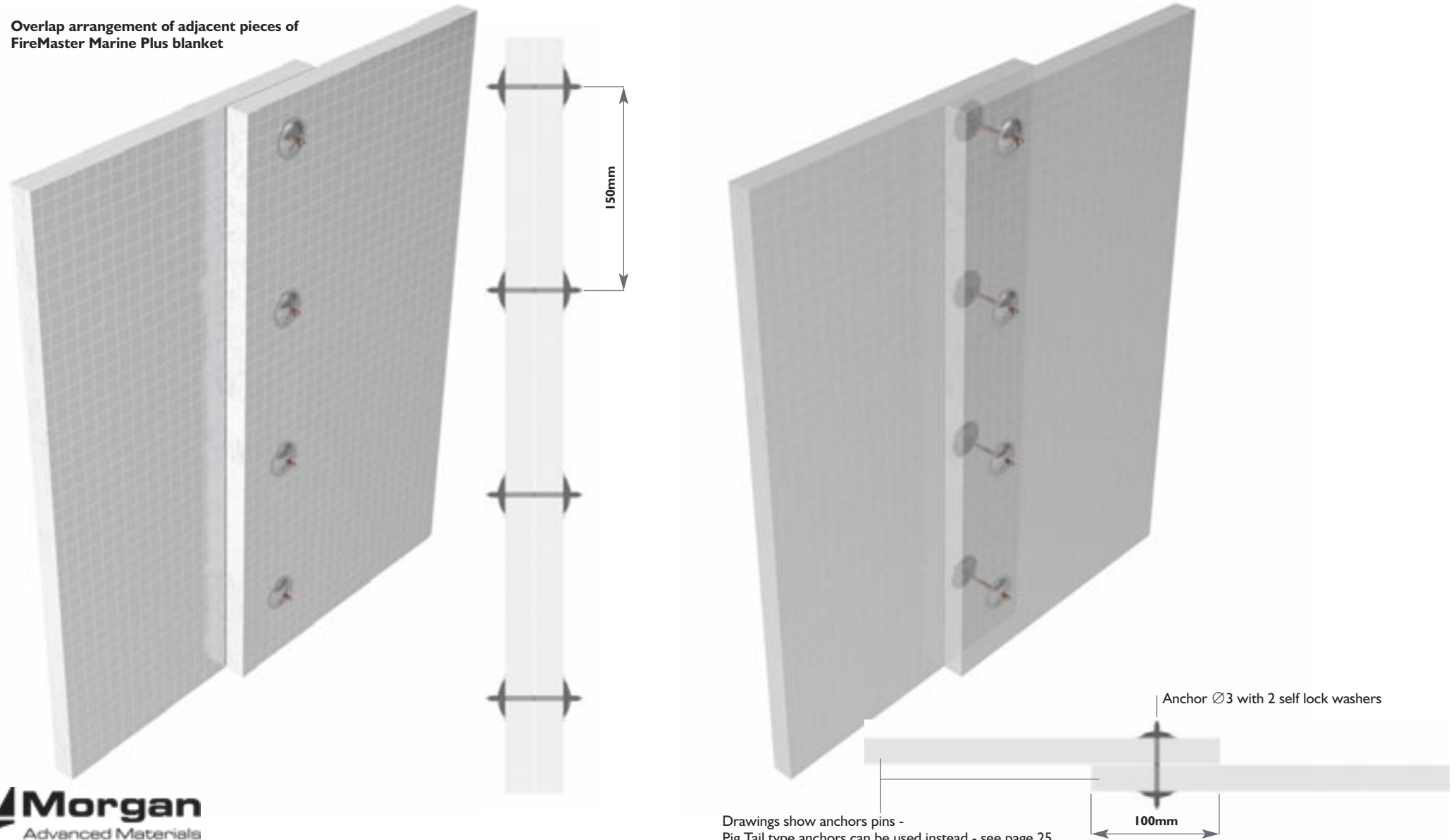

B15 wall extension system

Detail views

Cover strip applied when blanket is cut to allow penetration of cable tray

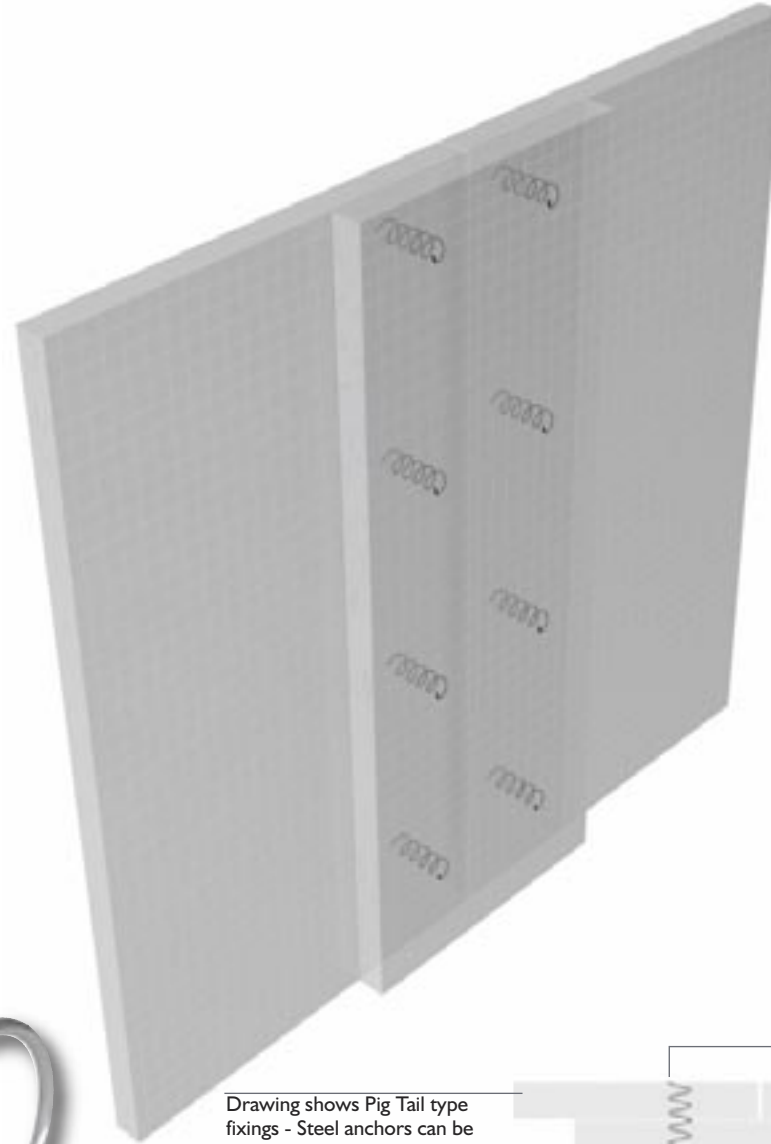
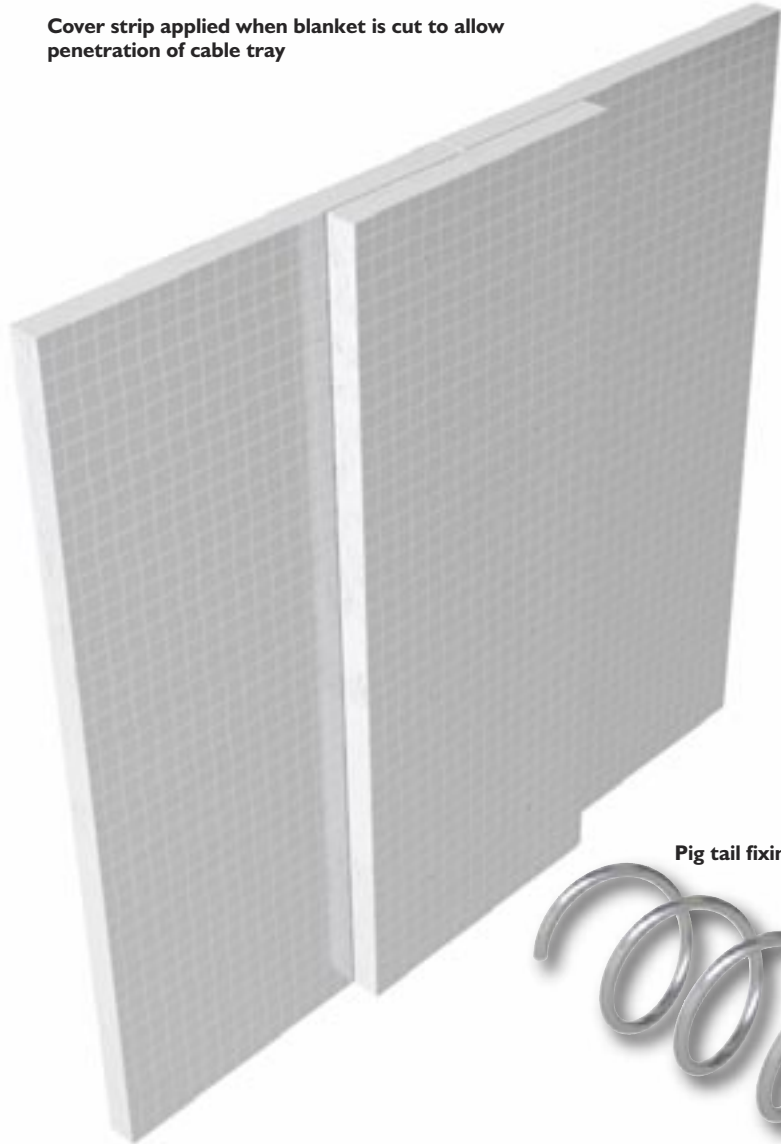

Pig tail fixing



150mm

Drawing shows Pig Tail type fixings - Steel anchors can be used instead - see page 24
FireMaster Marine Plus blanket - 80kg/m³ 25mm thickness with aluminium foil facing on both sides

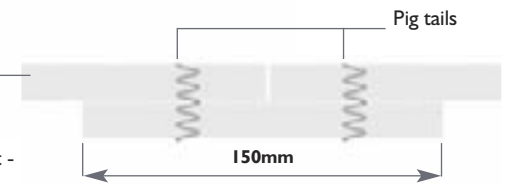

Pig tails

150mm

B15 wall extension system

Detail views

Fixing of B15 curtain to deck above

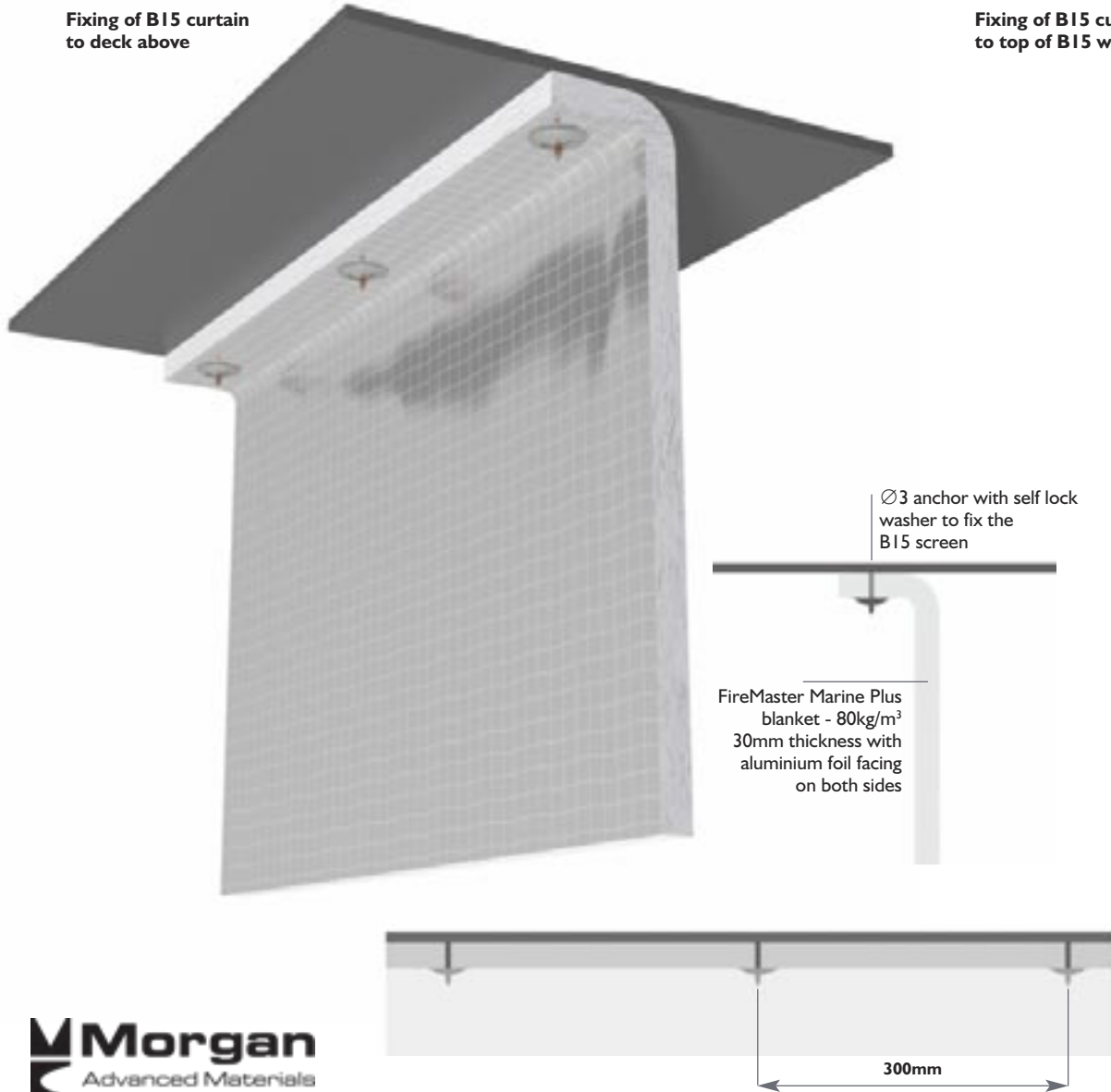

Fixing of B15 curtain to top of B15 wall

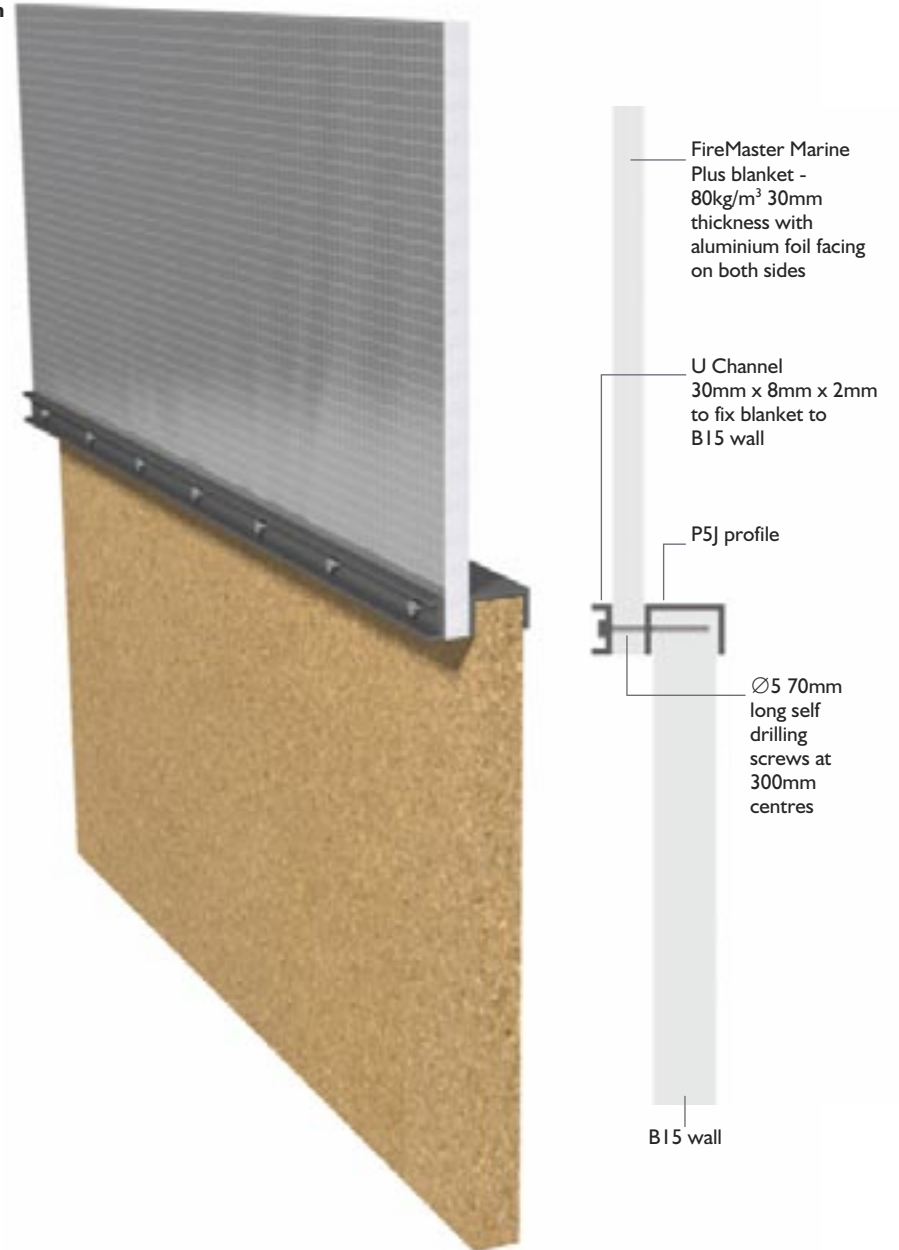



SOLAS 'Safe Return to Port' regulations

SOLAS 'Safe Return to Port' regulations lightweight fire insulation for fire protection of steel pipes

Background to the need for fire protection of steel pipes in ships

SOLAS regulation Chapter II-2/21.1 requires that passenger ships constructed on or after 1 July 2010 having a length of 120 metres or more, or having 3 or more main vertical fire zones, shall comply with design criteria for a 'Safe Return to Port' of the ship under its own propulsion after a fire casualty.

Section 4 of Regulation 21 lists all 'essential systems' which are required to ensure propulsion and manoeuvrability after a casualty not exceeding the 'casualty threshold', and also to maintain safety in all parts of the ship not affected by the casualty, as well as to ensure services needed to be available in safe areas.

IMO MSC.1/Circular 1369 provides additional guidance for the uniform implementation of SOLAS II-2 21.

Steel pipes that are part of an essential service which must remain operational in a fire, for example sprinkler system pipes, can be protected using FireMaster Marine Plus blanket for compliance with Regulation II-2/21.4 in accordance with IMO MSC.1/Circ. 1369 Interpretation 12.

IMO MSC.1/Circ 1369 Interpretation 12

"Steel pipes other than those carrying flammable liquids and passing through (not serving) spaces affected by a fire casualty may be considered to remain operational provided they are of substantial thickness (reference can be made to ICLL 66 regulation 22(3), as interpreted by IACS UI LL36/Rev. 2 paragraph (b)) or A-60 insulated (A-60 Class insulation approved in accordance with resolution A.754(18)¹ for bulkheads or decks may be used for this purpose). In both cases the pipes should be adequately supported. In order to be considered as remaining operational after a fire casualty, steel pipes should be joined by welding otherwise mechanical joints should be tested according to IACS UR P2.11.5.5.6 fire test or equivalent to the satisfaction of the Administration.

Temperature increase of liquids carried may need to be considered, and measures taken where necessary, so that the performance and purpose of the affected systems can be maintained as intended after the casualty has occurred."

¹ This resolution is superseded by IMO 2010 FTP Code Part 3

FireMaster Marine Plus systems for fire protection of steel pipes in accordance with MSC.1/Circ. 1369 Interpretation 12

Product	System specification	Weight (kg/m ²)
FireMaster Marine Plus blanket	45mm x 64kg/m ³ in single layer	2.88
FireMaster Marine Plus blanket	50mm x 48kg/m ³ in single layer	2.40

Lightweight fire insulation for fire protection of steel pipes

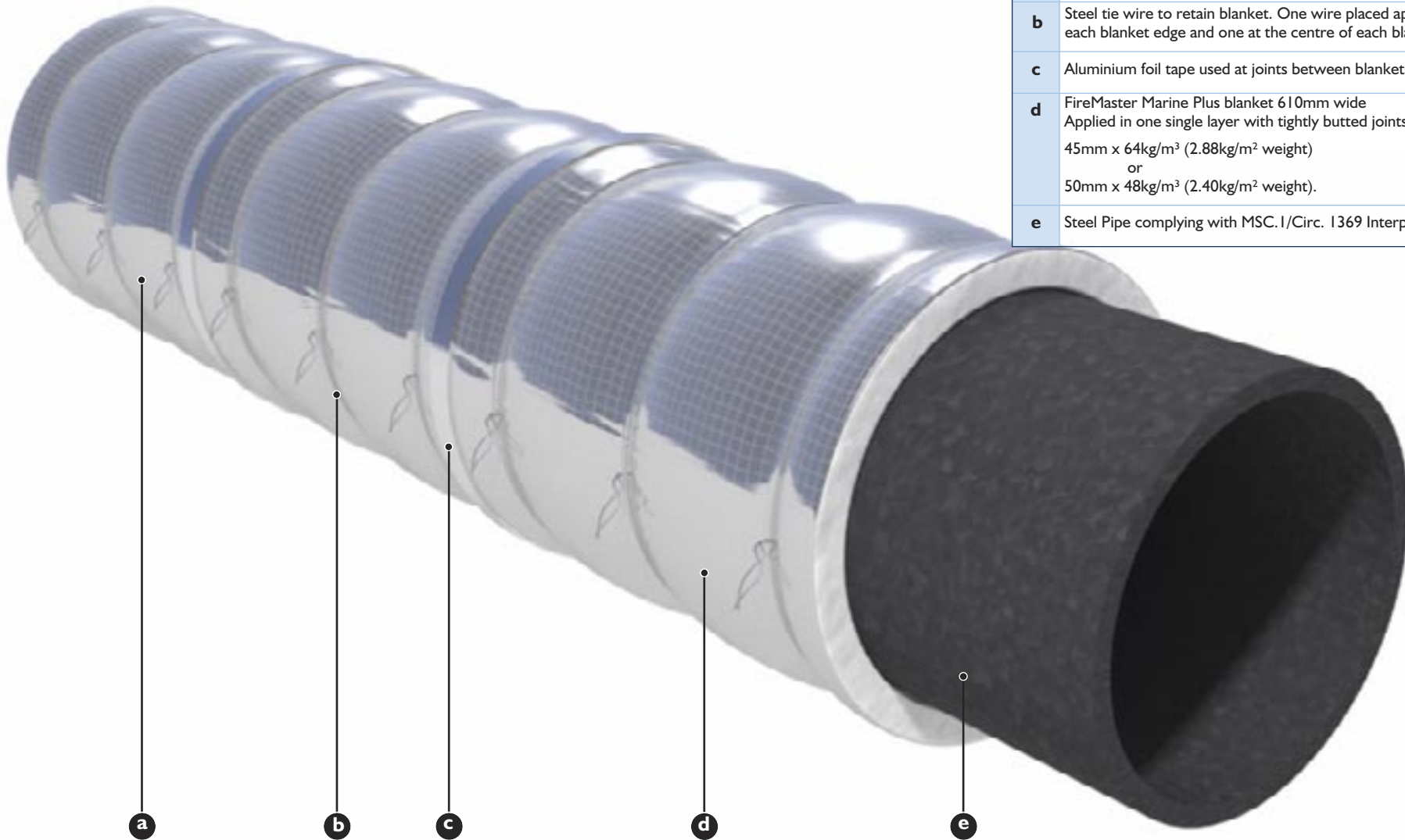

Ref.	Product
a	Outer facing of aluminium foil. FireMaster Marine Plus blanket is supplied with aluminium or glass cloth facing or alternatively, fully encapsulated with aluminium foil.
b	Steel tie wire to retain blanket. One wire placed approximately 50 to 75mm from each blanket edge and one at the centre of each blanket.
c	Aluminium foil tape used at joints between blankets.
d	FireMaster Marine Plus blanket 610mm wide Applied in one single layer with tightly butted joints : 45mm x 64kg/m ³ (2.88kg/m ² weight) or 50mm x 48kg/m ³ (2.40kg/m ² weight).
e	Steel Pipe complying with MSC.1/Circ. 1369 Interpretation 12.



FIREMASTER®



A60 aluminium deck and bulkhead

Profile wrap system

A60 aluminium deck and bulkhead

FireMaster® Marine Plus blanket is applied using bi-metallic anchors welded to the structure at a uniform anchor spacing of 200mm, meaning that joints between blankets can be placed at any point, leading to simpler installation.



Typical A60 system weight - 3.5kg/m²



A60 aluminium deck

Profile wrap system

FireMaster Marine Plus blanket 70kg/m³

Ref.	Product	Thickness (mm)	Weight (kg/m ²)
a	FireMaster Marine Plus blanket 70kg/m ³ .	50	3.5
b	FireMaster Marine Plus blanket 70kg/m ³ .	50	3.5

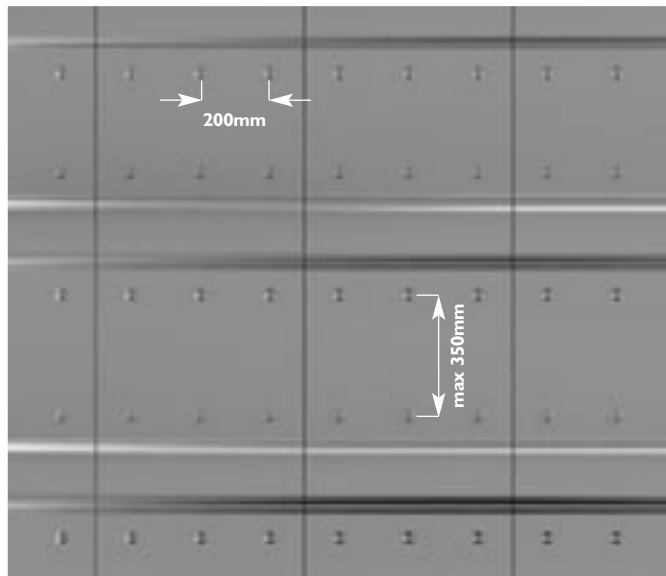

Detail of uniform deck anchor pattern

Anchors spaced at 200mm uniform centres across blanket width. Joints between adjacent blankets can be up to 100mm from anchor.

NB: All illustrations shown with un-taped joints



Detail of stiffener and flat layer system (main illustration right)

A60 aluminium bulkhead

Fire towards insulated side
Profile wrap system

FireMaster Marine Plus blanket 70kg/m³

Ref.	Product	Thickness (mm)	Weight (kg/m ²)
a	FireMaster Marine Plus blanket 70kg/m ³ .	50	3.5



Detail of stiffener and flat layer system

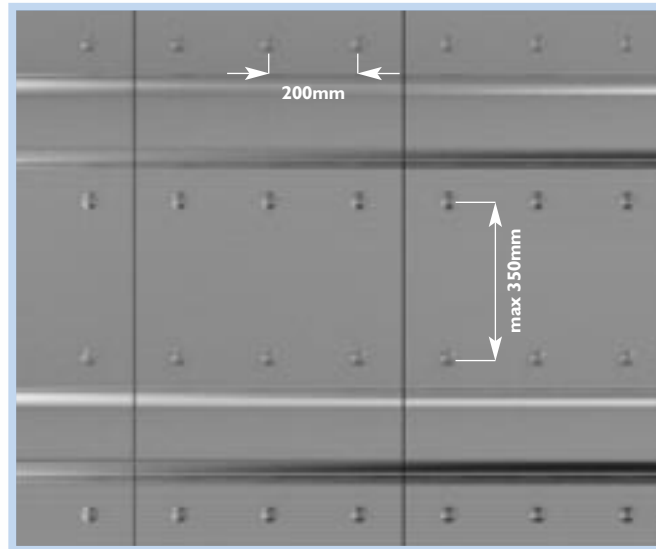

Detail of uniform bulkhead anchor pattern (main illustration right)

Anchors spaced at 200mm uniform centres across blanket width.
Joints between adjacent blankets can be up to 100mm from anchor.

NB: All illustrations shown with un-taped joints

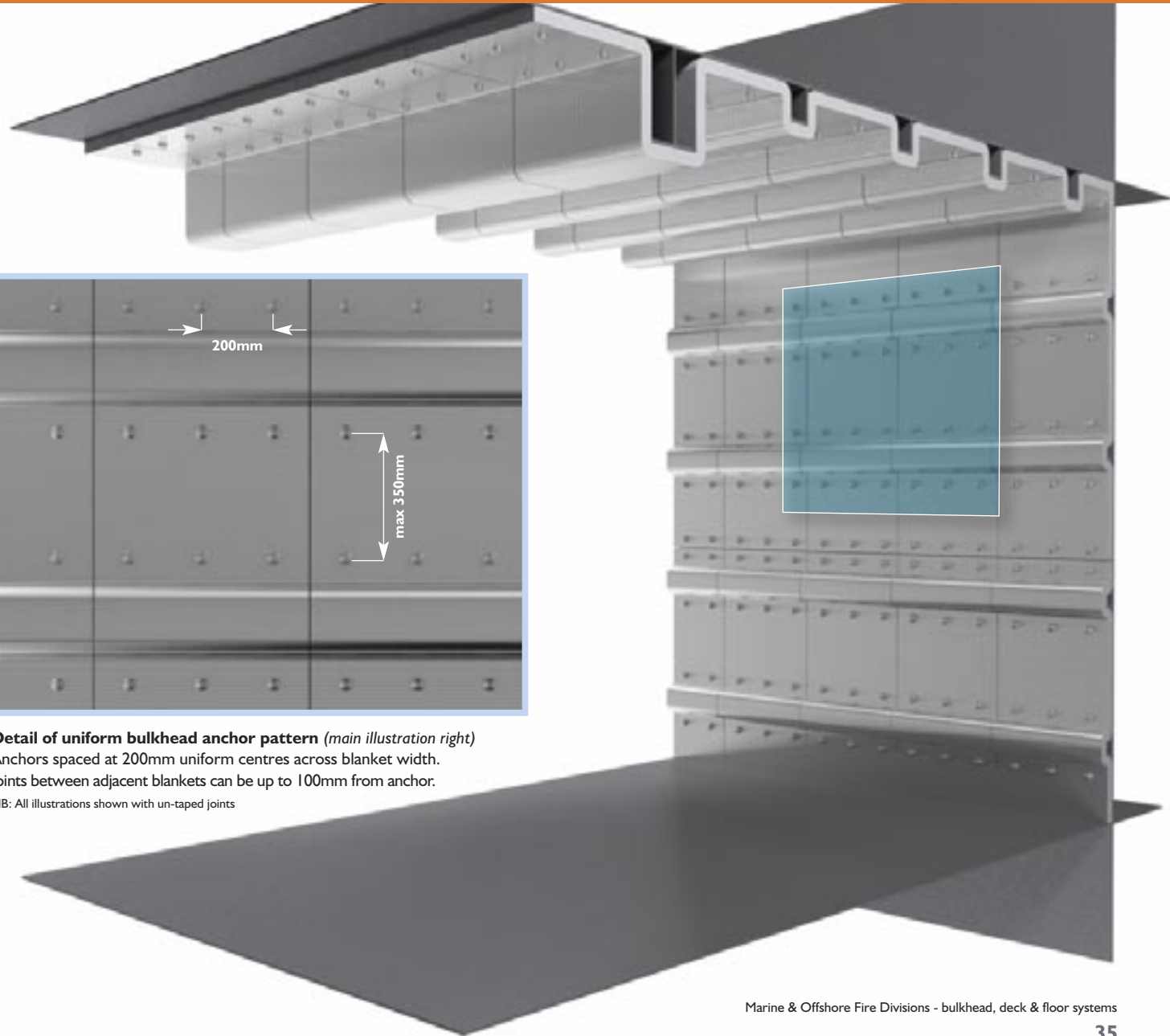

A60 aluminium bulkhead

Fire towards either side
Profile wrap system

FireMaster Marine Plus blanket 70kg/m³

Ref.	Product	Thickness (mm)	Weight (kg/m ²)
a	FireMaster Marine Plus blanket 70kg/m ³ .	50	3.5
b	Aluminium bulkhead.	6	-
c	FireMaster Marine Plus blanket 70kg/m ³ .	50	3.5

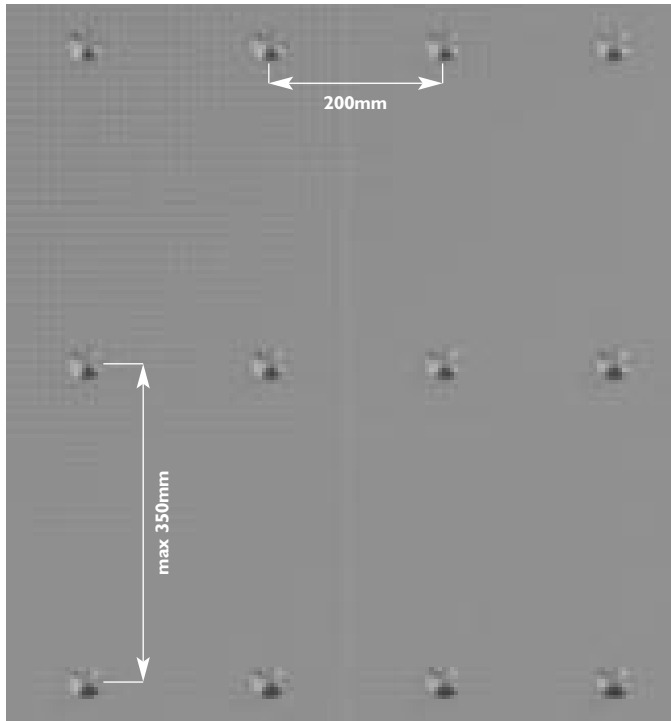

Detail of non-stiffened side blanket layout

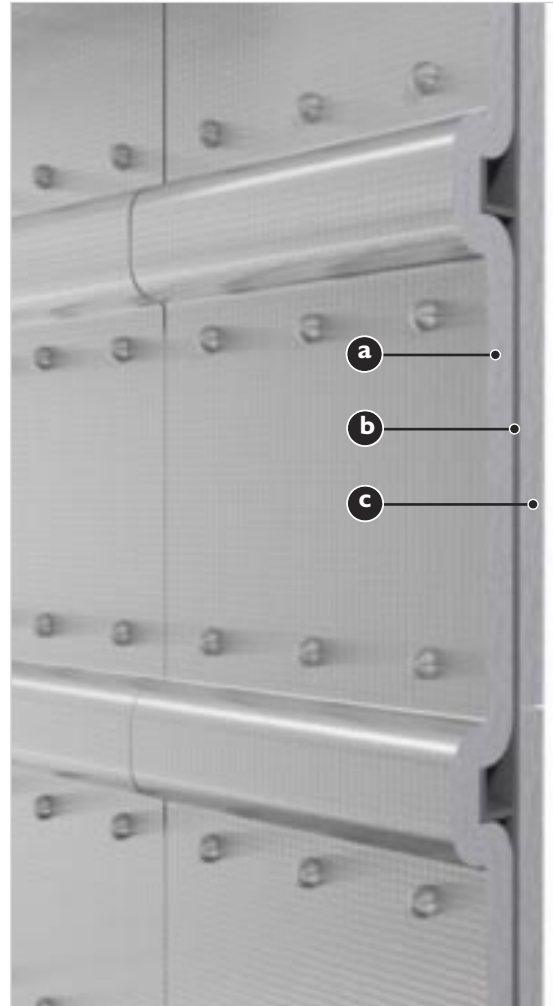

Detail of FireMaster Marine Plus blanket applied on each side of the bulkhead in one single layer

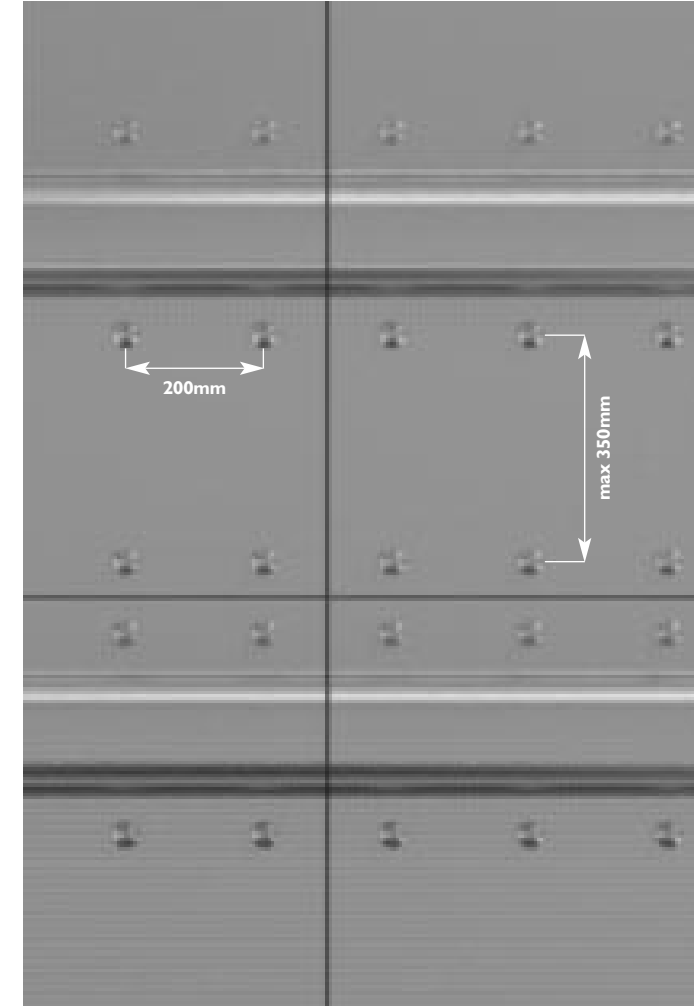

Detail of stiffened side blanket layout

Vertical anchor spacing depends on stiffener spacing
Maximum spacing 300mm to 350mm

NB: All illustrations shown with un-taped joints

Loadbearing aluminium divisions for high speed craft (HSC)

Profile wrap system

Loadbearing aluminium divisions for decks and bulkheads

Special systems are available for the thin (2mm thick) structures used in high-speed craft with a weight of 3.5kg/m² for 60 minutes fire protection and simple installation utilising an air gap between the structure and the installation.

FIREMASTER



60 minutes fire protection



Loadbearing aluminium divisions - deck

2mm plate
Profile wrap system

60 minute system

See tables on page 72 for details of 30 minute system

Ref.	Product	Thickness (mm)	Weight (kg/m ²)
a	FireMaster Marine Plus blanket 70kg/m ³ .	50	3.5
b	FireMaster Marine Plus blanket 70kg/m ³ .	50	3.5

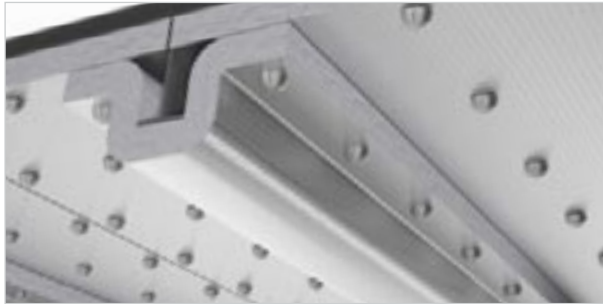

Detail of wrapping of deck stiffener

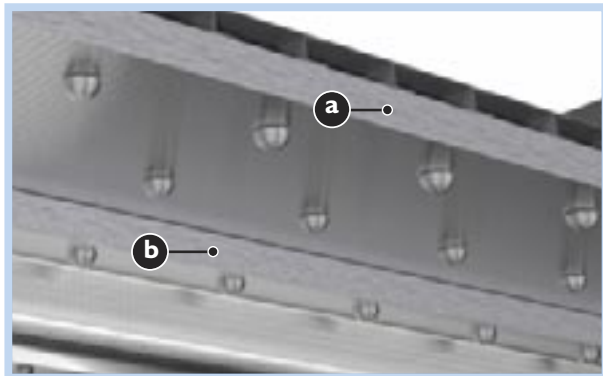

Detail of 60 minute load-bearing aluminium deck
(main illustration right)



Detail of uniform deck anchor pattern (main illustration right)

Blanket installed flat under stiffeners with aluminium foil between air gap and blanket.

Anchors fixed to alternate stiffeners.

Anchor spacing dependant on stiffener, maximum distance 300mm.

NB: All illustrations shown with un-taped joints

Loadbearing aluminium divisions - bulkhead

2mm plate
Profile wrap system

60 minute system

See tables on page 72 for details of 30 minute system

Ref.	Product	Thickness (mm)	Weight (kg/m ²)
a	FireMaster Marine Plus blanket 70kg/m ³ .	50	3.5
b	FireMaster Marine Plus blanket 70kg/m ³ .	50	3.5



Detail of 60 minute load-bearing aluminium bulkhead

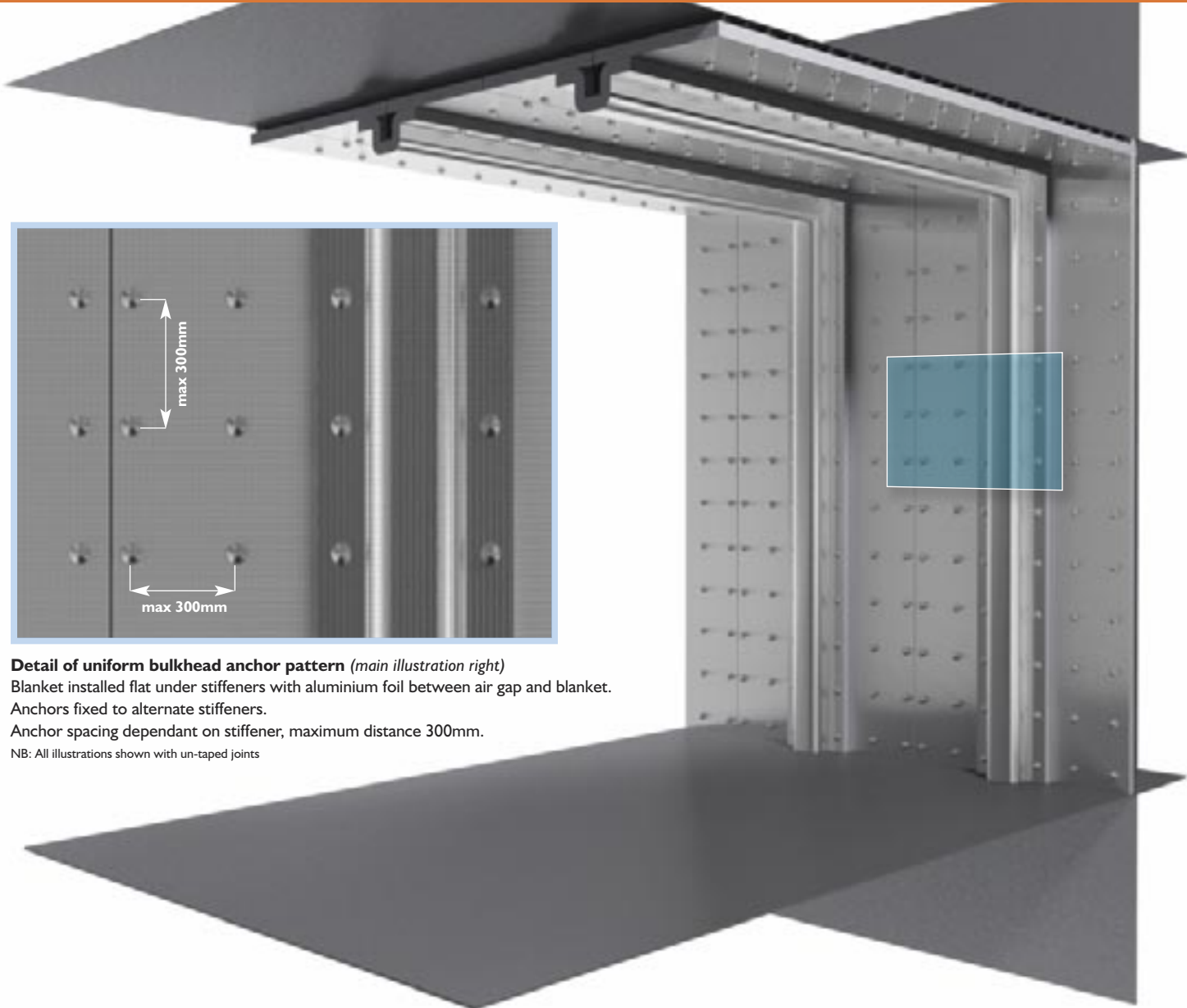

Detail of uniform bulkhead anchor pattern (main illustration right)

Blanket installed flat under stiffeners with aluminium foil between air gap and blanket.

Anchors fixed to alternate stiffeners.

Anchor spacing dependant on stiffener, maximum distance 300mm.

NB: All illustrations shown with un-taped joints

Bi-metallic anchor system for aluminium decks and bulkheads

Fixing anchors - anchor types used

FireMaster blanket is normally held in place using 3mm diameter fixing pins over which the blanket is impaled. A friction fit washer secures the blanket onto the pin.

The standard recommended fixing method for aluminium substrates is a bi-metallic anchor system. This consists of a 3mm diameter mild or stainless steel shaft that is screw threaded into an aluminium boss which can be CD welded to aluminium. The blanket is usually held in place with a 38mm diameter mild or stainless steel friction fit washer. Smaller diameter washers may also be used.

Number of anchors needed

See the individual system information sheets, throughout this manual, for the exact anchor layout for each system.

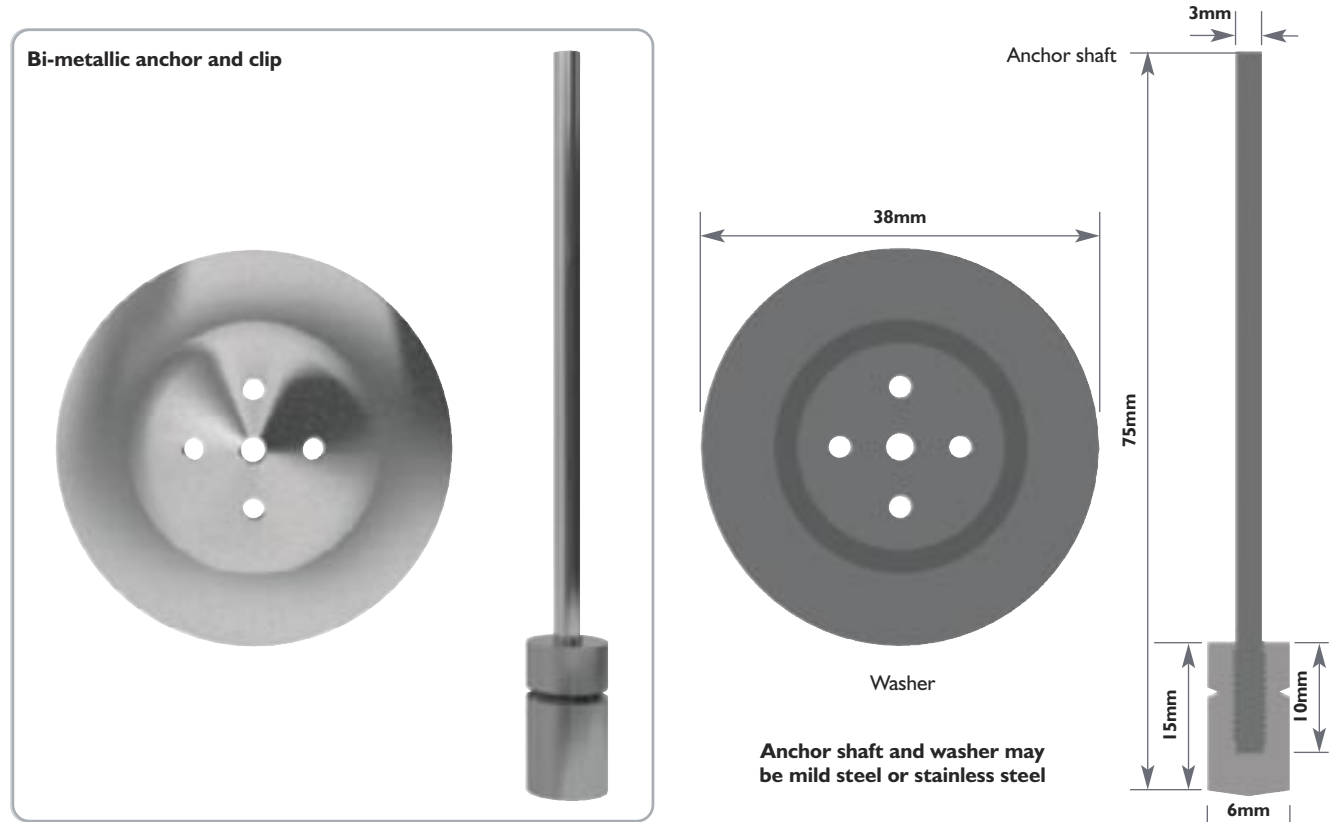

Loadbearing FRP composite divisions for high speed craft (HSC)

Profile wrap system

Loadbearing FRP composite divisions for decks and bulkheads

FireMaster® Marine Plus blanket is fully fire tested for the protection of the structure of FRP sandwich panel type bulkheads and decks. DNV and MED Type Approved systems are available for both 30 and 60 minute fire rated divisions.

FIREMASTER®



DNV and MED Type Approved systems



Loadbearing FRP composite divisions - deck

Profile wrap system

60 minute system

See tables on page 73 for details of 30 minute system

Ref.	Product	Thickness (mm)	Weight (kg/m ³)
a	FireMaster Marine Plus blanket 64kg/m ³ .	25	1.6
b	FireMaster Marine Plus blanket 70kg/m ³ .	25	1.75
c	FireMaster Marine Plus blanket 70kg/m ³ .	25	1.75
d	FireMaster Marine Plus blanket 70kg/m ³ .	25	1.75

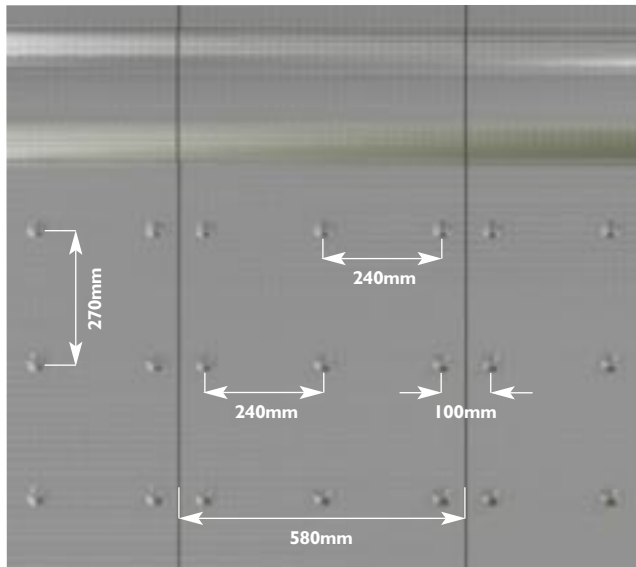

Detail of deck anchor pattern (main illustration right)

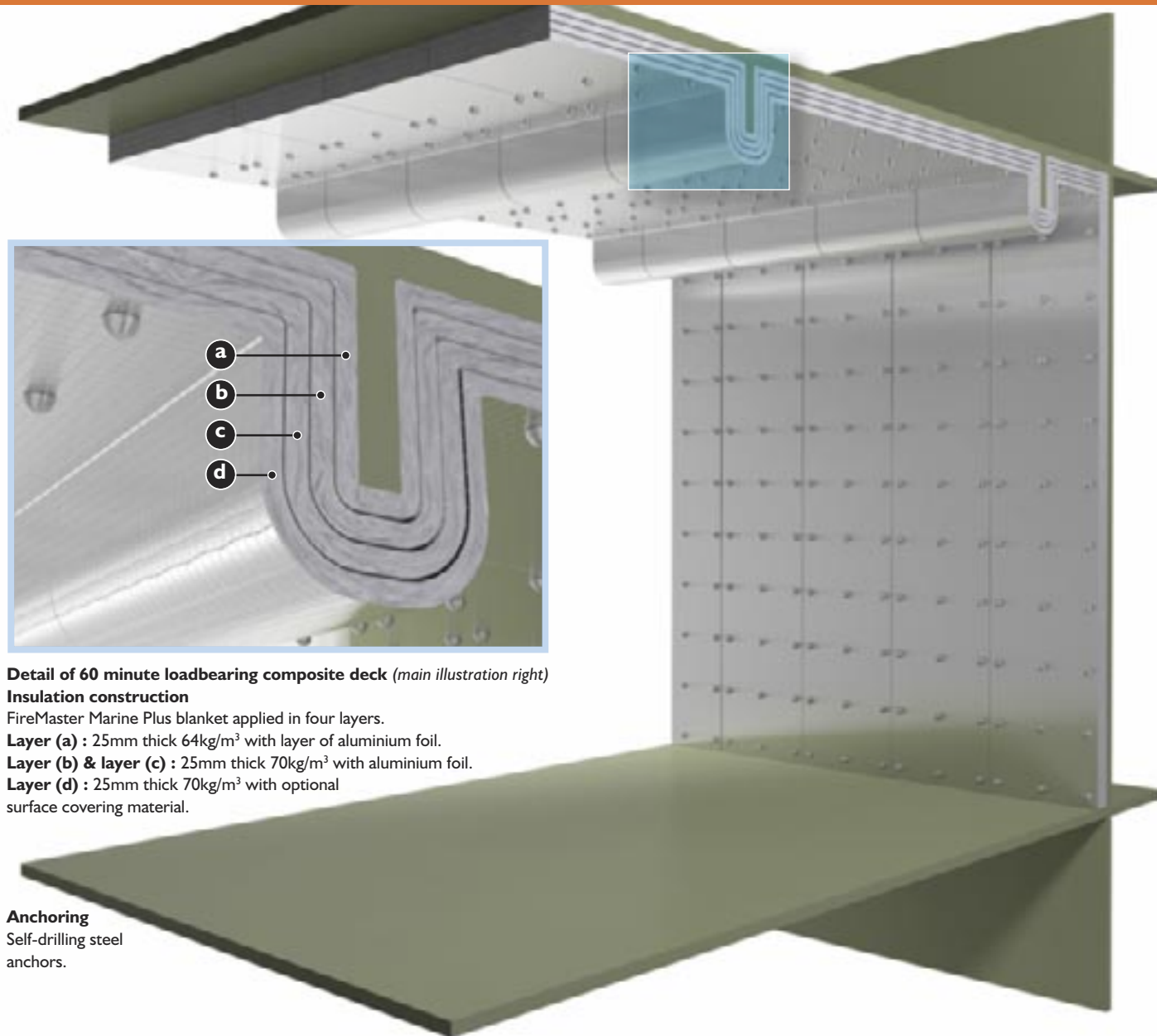

Detail of 60 minute loadbearing composite deck (main illustration right)

Insulation construction

FireMaster Marine Plus blanket applied in four layers.

Layer (a) : 25mm thick 64kg/m³ with layer of aluminium foil.

Layer (b) & layer (c) : 25mm thick 70kg/m³ with aluminium foil.

Layer (d) : 25mm thick 70kg/m³ with optional surface covering material.

Anchoring

Self-drilling steel anchors.

Loadbearing FRP composite divisions - bulkhead

Profile wrap system

60 minute system

See tables on page 73 for details of 30 minute system

Ref.	Product	Thickness (mm)	Weight (kg/m ²)
a	FireMaster Marine Plus blanket 64kg/m ³ .	25	1.6
b	FireMaster Marine Plus blanket 70kg/m ³ .	25	1.75
c	FireMaster Marine Plus blanket 70kg/m ³ .	25	1.75
d	FireMaster Marine Plus blanket 70kg/m ³ .	25	1.75

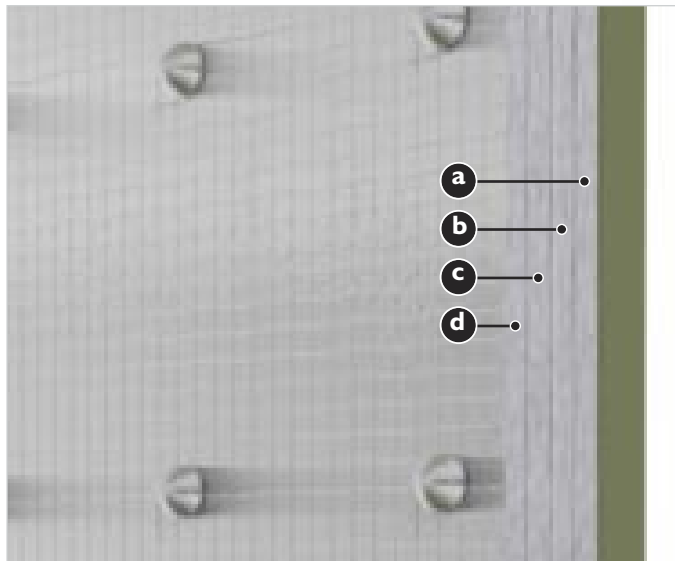

Detail of 60 minute loadbearing composite bulkhead (main illustration right)

Insulation construction

FireMaster Marine Plus blanket applied in four layers.

Layer (a) : 25mm thick 64kg/m³ with layer of aluminium foil.

Layer (b) & layer (c) : 25mm thick 70kg/m³ with aluminium foil.

Layer (d) : 25mm thick 70kg/m³ with optional surface covering material.

Anchoring

Self-drilling steel anchors.

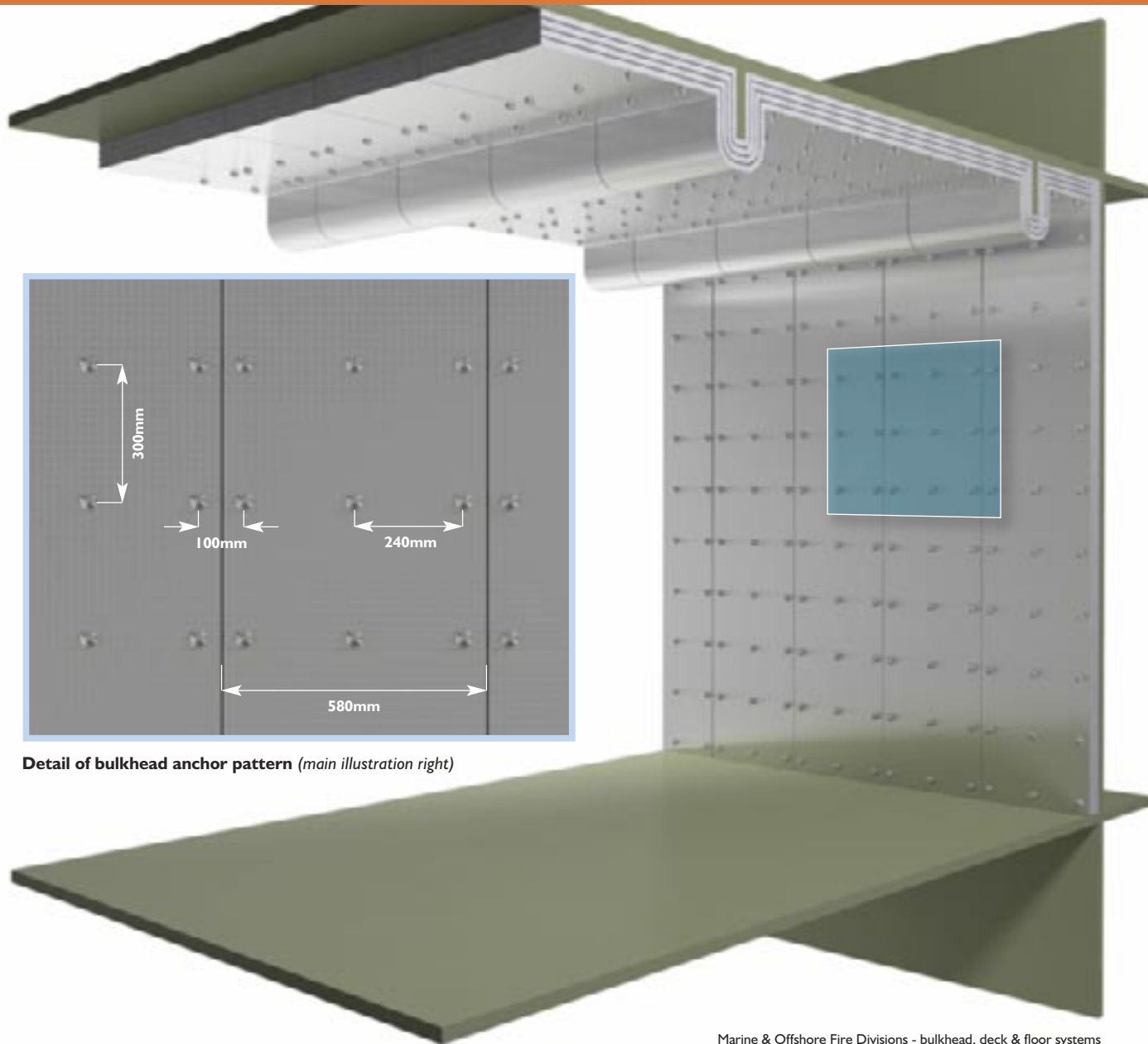

Detail of bulkhead anchor pattern (main illustration right)

Anchor system for FRP composite divisions - decks and bulkheads

Fixing anchors - anchor types used

3mm diameter anchors and a friction fit washer are used to fix FireMaster blanket. The approved anchors are illustrated opposite. The anchor pin consists of a 3mm stainless or mild steel pin welded to a 6mm diameter, minimum 25mm long self-drilling screw.

The screw end is fixed into the composite core.

The blanket lining is impaled over the pin and retained with a friction fit washer.

Installation utilises a drill with screw fix attachment and is very fast.

Number of anchors needed

See the individual system information sheets, throughout this manual, for the exact anchor layout for each system.



Anchor fixing for composite sandwich bulkheads and decks

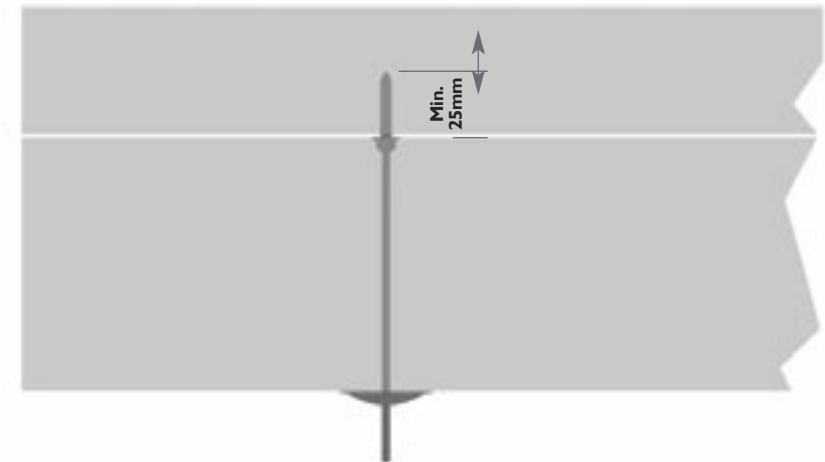



Blast resistance of FireMaster[®] fire divisions

Blast resistance of FireMaster® fire divisions

FireMaster® Marine Plus fire divisions have been subjected to blast testing to provide the required test evidence to support their use in areas where explosion hazards may be present.

FIREMASTER®



On offshore structures the risk of an explosion and subsequent hydrocarbon pool or jet fire requires that fire divisions are sometimes also required to be resistant to explosion overpressure as well as fire. FireMaster Marine Plus fire divisions have been subjected to blast testing to provide the required test evidence to support their use in areas where explosion hazards may be present.

Blast testing technical design

FireMaster Marine Plus blanket has good blast pressure resistance, being capable of absorbing the pressure of an explosion. The key design requirements are to ensure the integrity of the fixing system that supports the blanket onto the insulated structure and to protect the blanket surface from surface erosion by velocities generated in a gas explosion. The main elements of the design of a blast-resistant fire insulation system using FireMaster Marine Plus blanket are the use of surface protection meshes and attention to the design of the anchor retention system. Morgan Advanced Materials engineers will be pleased to give advice on these design details.



Blast testing

In the DNV-GL Spadeadam test site gas explosion chamber, **two consecutive blast tests** were carried out on samples of the FireMaster Marine Plus H60 deck system, witnessed by Lloyds Register of Shipping and DNV. The blast exposed test specimens were subsequently examined and independently assessed for any damage to the system that would be likely to impair their fire integrity.

Summary of blast testing and results

1. The test panels were exposed to blast overpressure on the **stiffened** face, representing realistic, severe, exposure conditions for a deck as the insulation is wrapped around stiffener sections that can distort with reaction to the blast.
2. Each panel was subjected to **two consecutive** blast tests with increased overpressure used in the second test.
3. Damage noted in all tests on all specimens was insignificant due to the design of the retention support system utilised.

Blast pressure and duration	System with chicken wire mesh and glass cloth covering	System with stainless steel mesh covering
TEST 1 0.6 bar 123ms	Some washers lost on surface cover of glass cloth. No loss of washers retaining the FireMaster Marine Plus fire insulation	No damage
TEST 2 1.25 bar 128ms	Some more washers lost on surface cover of glass cloth. No loss of washers retaining the FireMaster Marine Plus fire insulation	Some loss of washers retaining the mesh. No loss of washers retaining the FireMaster Marine Plus fire insulation

Blast resistance of FireMaster® fire divisions

Stainless steel mesh covering

FireMaster Marine Plus blanket 70kg/m³

Ref.	Product
a	Stiffener packed with FireMaster Marine Plus blanket 70kg/m ³ .
b	FireMaster Marine Plus blanket 70kg/m ³ .
c	FireMaster Marine Plus blanket 70kg/m ³ .
d	Stainless steel wire mesh.
e	Copper coated mild steel CD welded anchors, end of anchor bent over after installation.

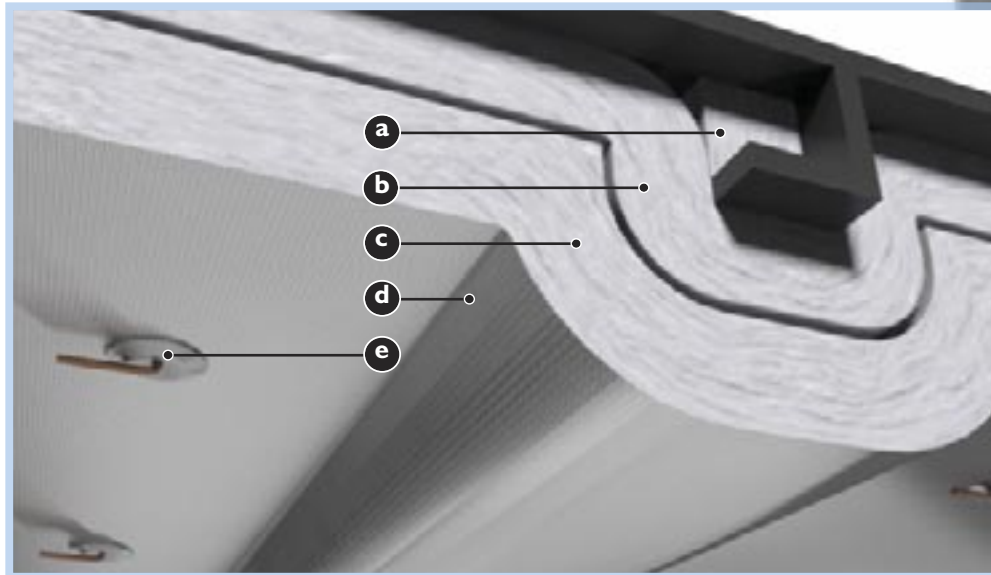

Detail of stiffener and flat layer system



Glass cloth covering

FireMaster Marine Plus blanket 70 kg/m³

Ref.	Product
a	Stiffener packed with FireMaster Marine Plus blanket 70 kg/m ³ .
b	FireMaster Marine Plus blanket 70 kg/m ³ .
c	FireMaster Marine Plus blanket 70 kg/m ³ .
d	Chicken wire mesh.
e	Glass cloth covering.
f	Copper coated mild steel CD welded anchors, end of anchor bent over after installation.

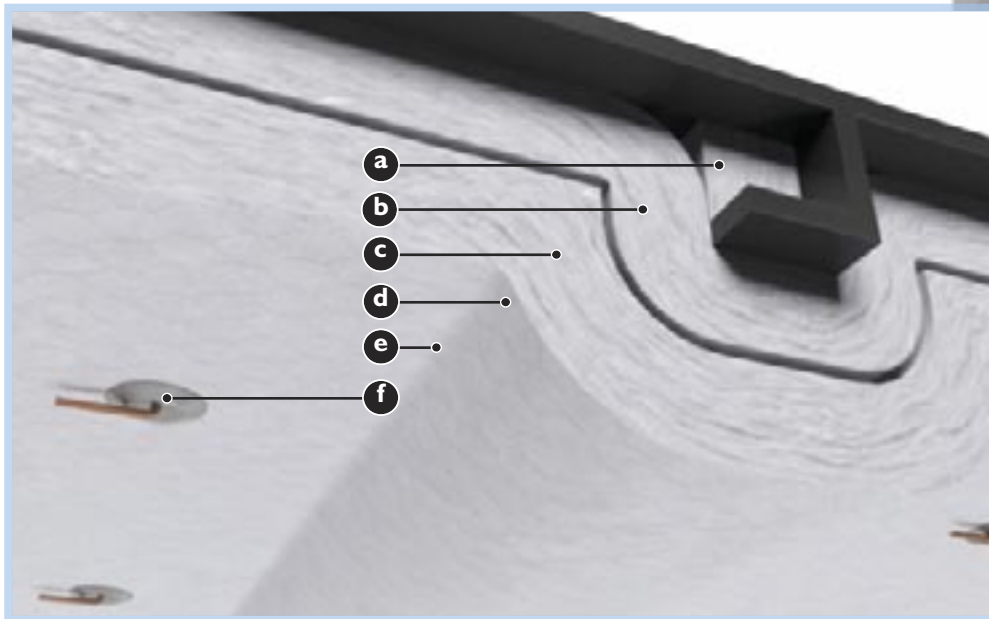

Detail of stiffener and flat layer system

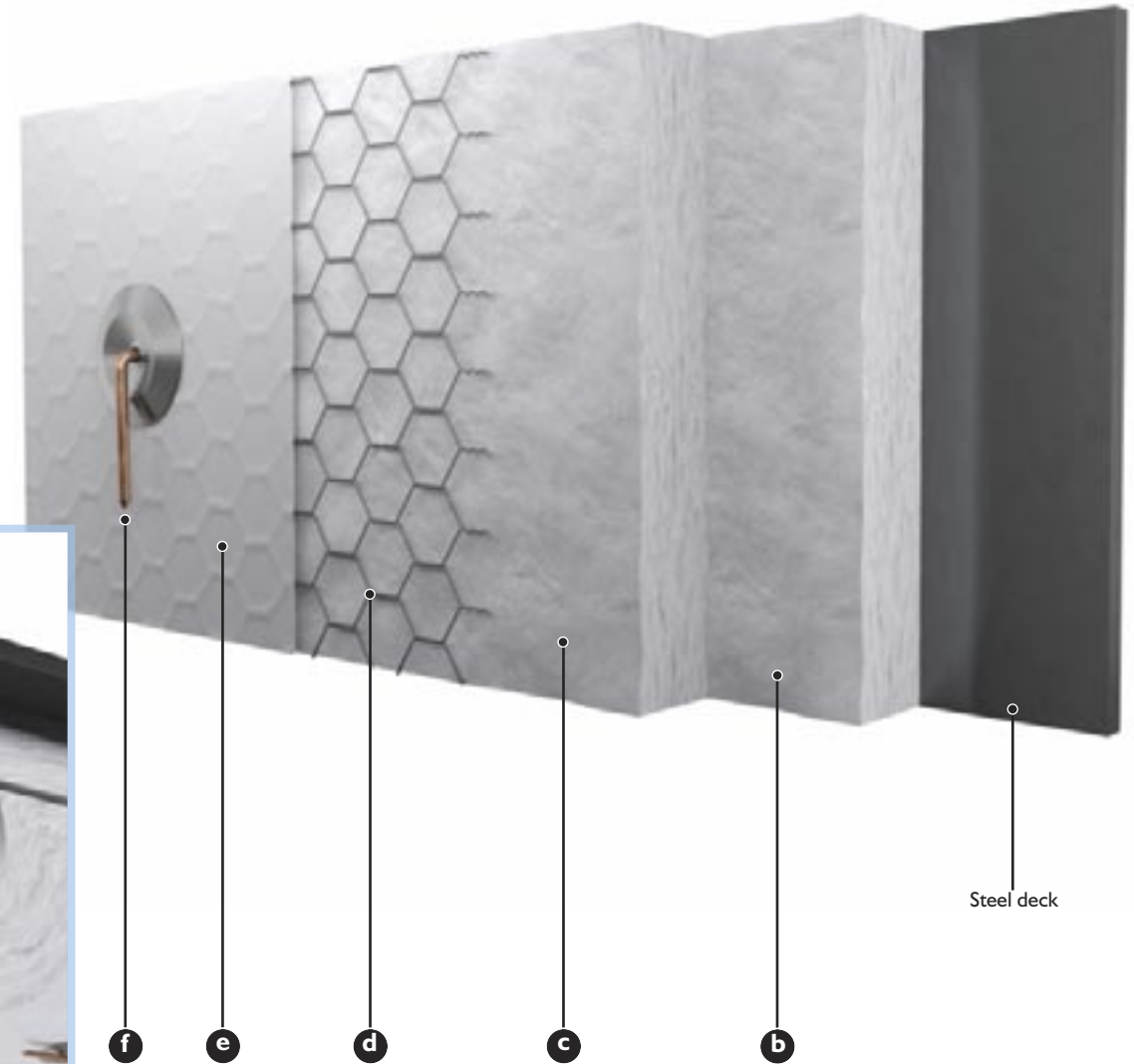



FIREMASTER[®]



H60 & H120 steel decks and bulkheads

H60 & H120 steel decks and bulkheads

Fire protection and thermal insulation on ships must meet very high requirements. These requirements demand alternative solutions for different fire applications. FireMaster® Marine Plus blanket has approvals for H60 and H120 steel decks and bulkheads.

FIREMASTER®





H60 steel deck

Profile wrap system

FireMaster Marine Plus blanket 70kg/m³

Ref.	Product	Thickness (mm)	Weight (kg/m ²)
a	FireMaster Marine Plus blanket 70kg/m ³ .	40	2.8
b	FireMaster Marine Plus blanket 70kg/m ³ .	40	2.8

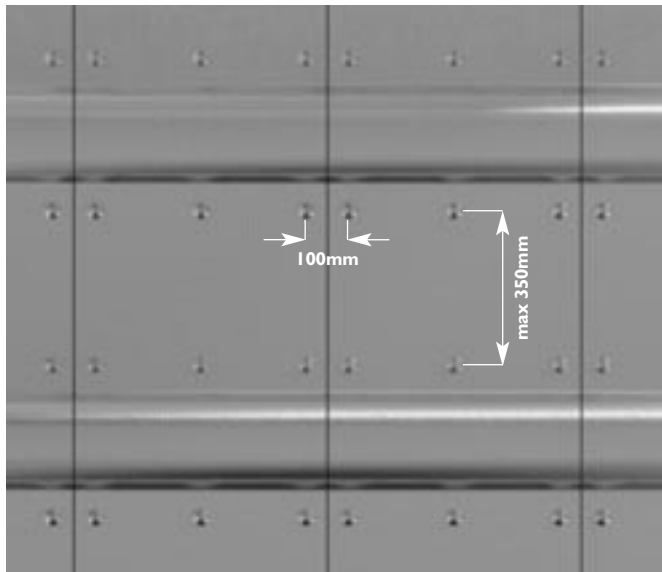

Detail of deck anchor pattern (main illustration right)

NB: All illustrations shown with un-taped joints

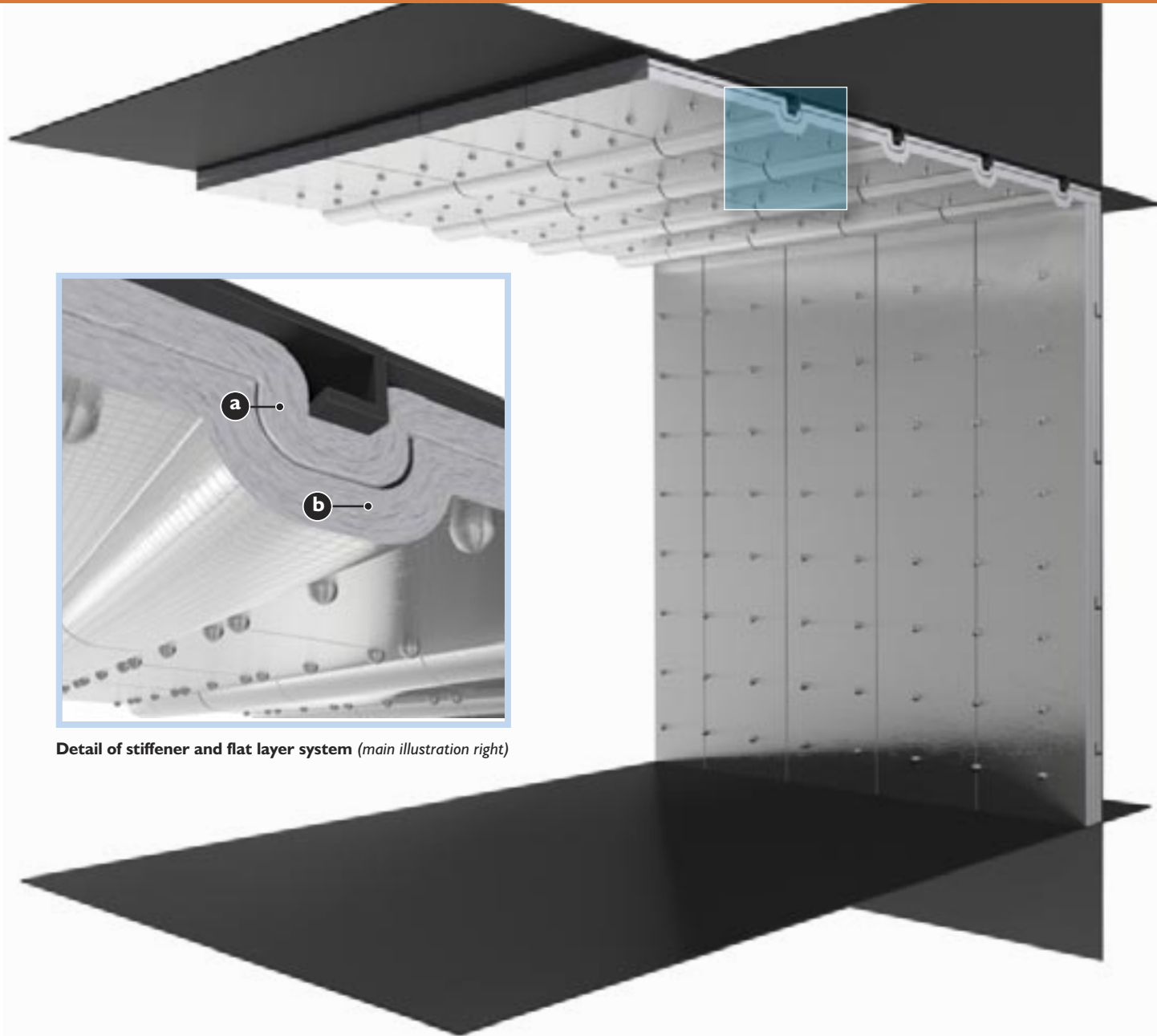

Detail of stiffener and flat layer system (main illustration right)

H60 steel bulkhead

Fire towards either side
Flat layer system

FireMaster Marine Plus blanket 70kg/m³

Ref.	Product	Thickness (mm)	Weight (kg/m ²)
a	FireMaster Marine Plus blanket 70kg/m ³ .	40	2.8
b	FireMaster Marine Plus blanket 70kg/m ³ .	40	2.8
c	FireMaster Marine Plus blanket 70kg/m ³ .	50	3.5

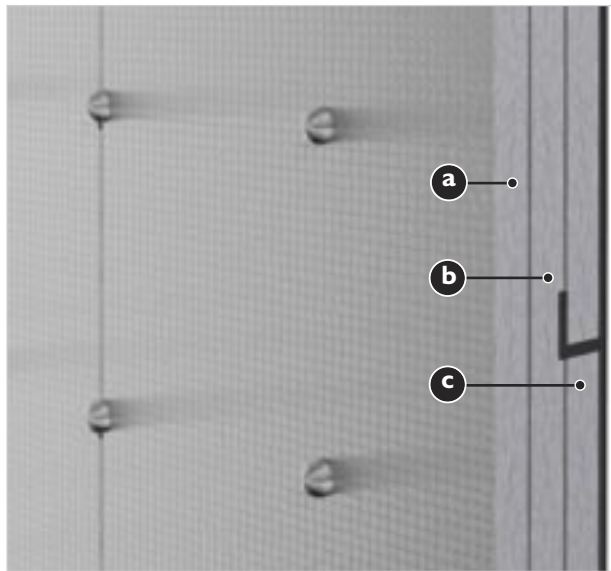

Detail of stiffener and flat layer system (main illustration right)

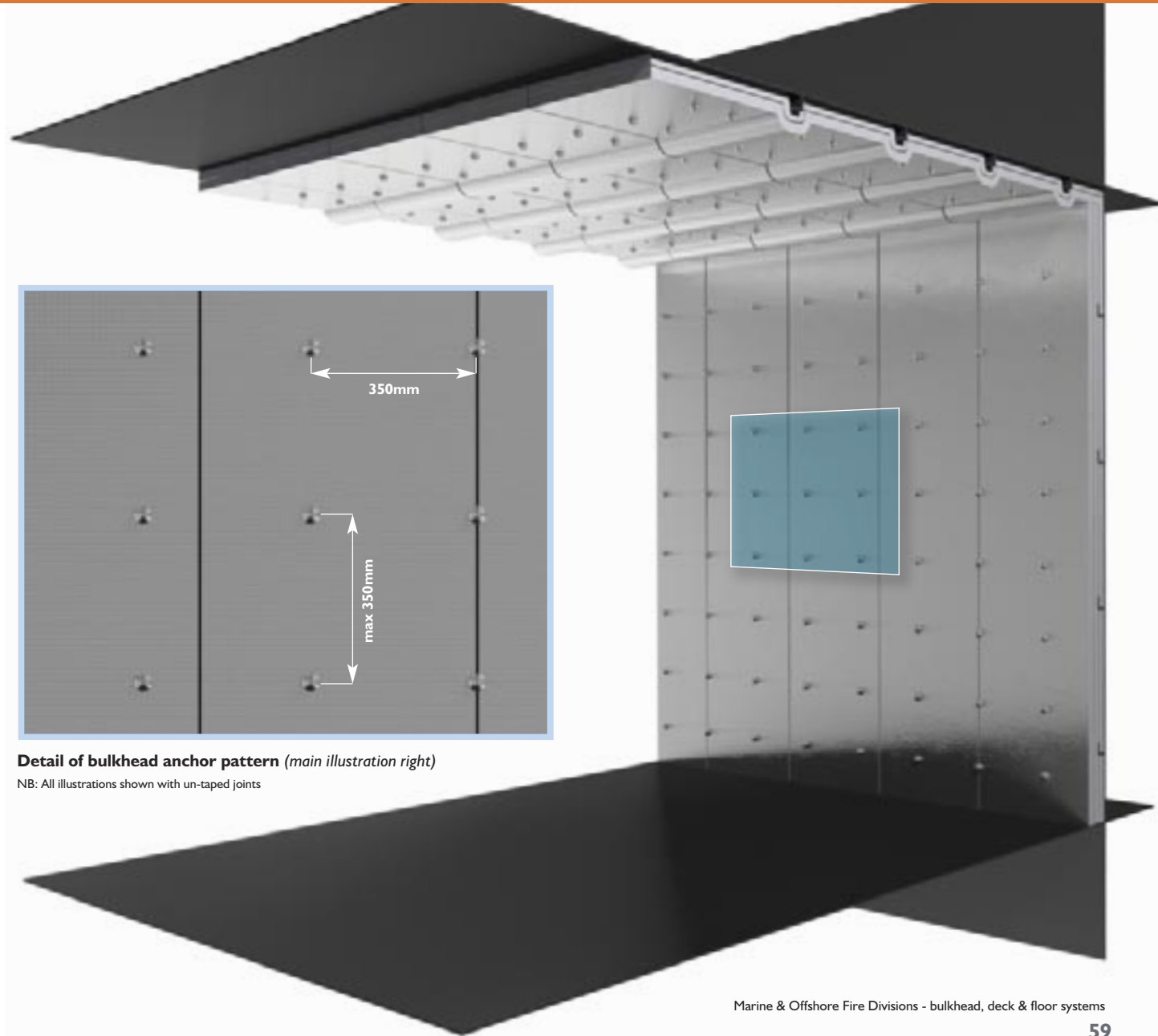

Detail of bulkhead anchor pattern (main illustration right)

NB: All illustrations shown with un-taped joints

H120 steel deck

Profile wrap system

FireMaster Marine Plus blanket 70kg/m³

Ref.	Product	Thickness (mm)	Weight (kg/m ²)
a	Stiffener packed with FireMaster Marine Plus blanket 70kg/m ³ .	-	-
b	FireMaster Marine Plus blanket 70kg/m ³ .	50	3.5
c	FireMaster Marine Plus blanket 70kg/m ³ .	60	4.2

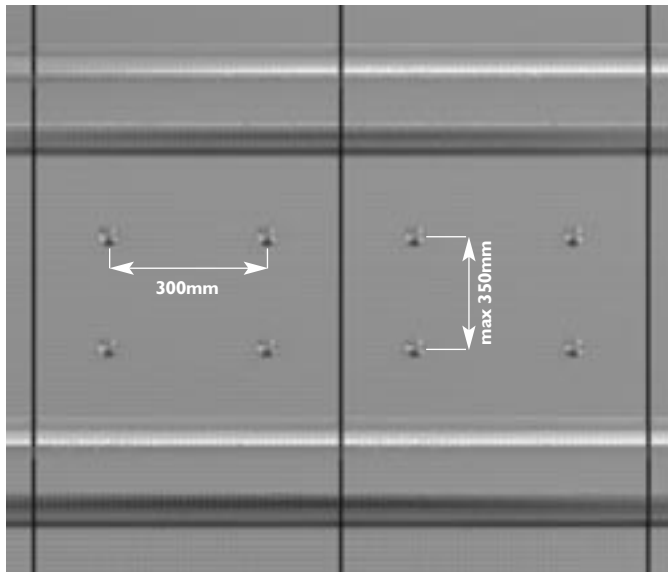

Detail of deck anchor pattern (main illustration right)

NB: All illustrations shown with un-taped joints

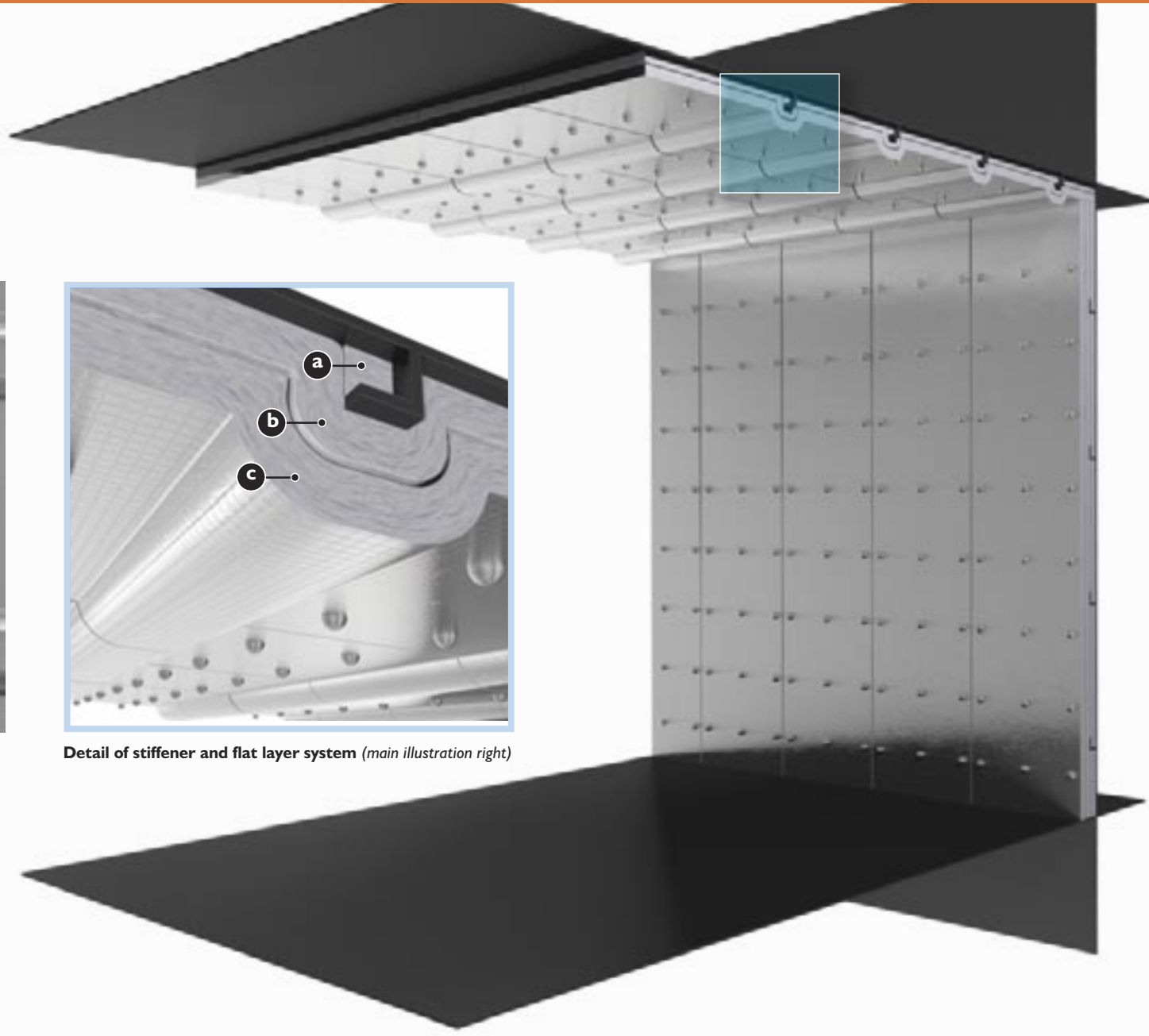

Detail of stiffener and flat layer system (main illustration right)

H120 steel bulkhead

Fire towards either side
Flat layer system

FireMaster Marine Plus blanket 70kg/m³

Ref.	Product	Thickness (mm)	Weight (kg/m ²)
a	FireMaster Marine Plus blanket 70kg/m ³ .	50	3.5
b	FireMaster Marine Plus blanket 70kg/m ³ .	50	3.5
c	FireMaster Marine Plus blanket 70kg/m ³ .	50	3.5

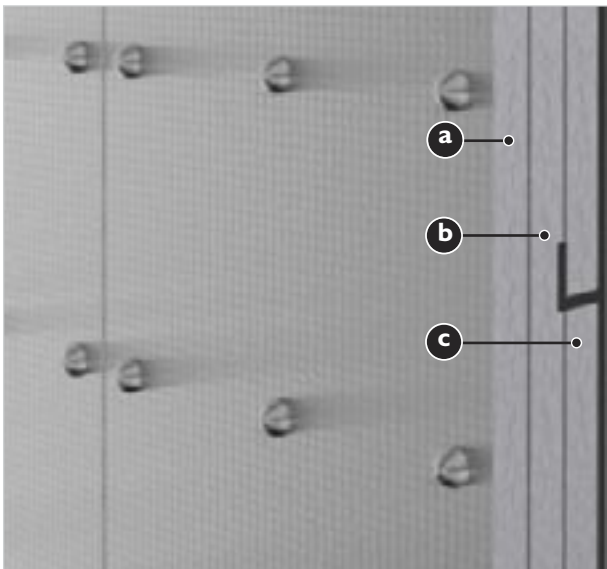

Detail of stiffener and flat layer system (main illustration right)

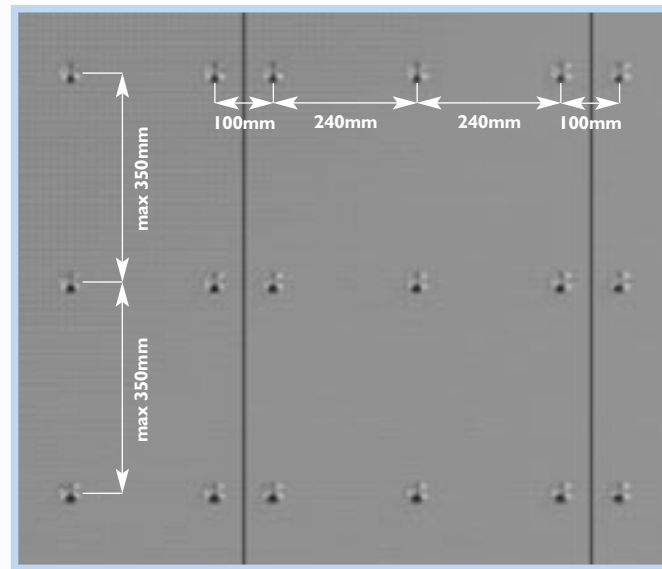

Detail of bulkhead anchor pattern (main illustration right)

NB: All illustrations shown with un-taped joints

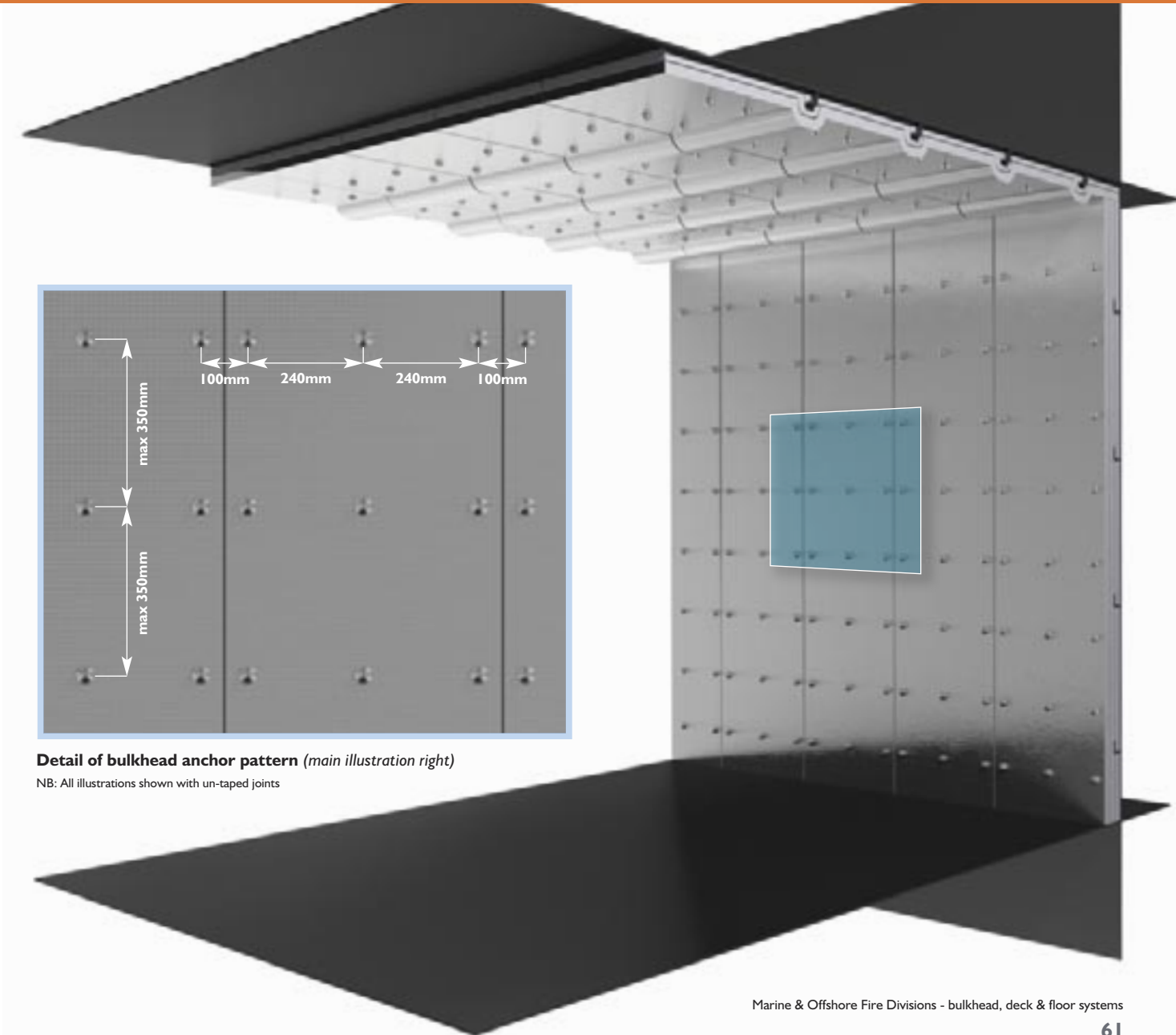

H60 / H120 corrugated steel fire wall

Fire towards either side
Flat layer system

H60 or H120 Corrugated Wall

Ref.	Product	Thickness (mm)	Weight (kg/m ²)
a	Stainless or mild steel corrugated plate.	2	-
b	FireMaster Marine Plus blanket 70kg/m ³ .	50	3.5
c	FireMaster Marine Plus blanket 70kg/m ³ .	50	3.5
d	FireMaster Marine Plus blanket 70kg/m ³ .	60	4.2

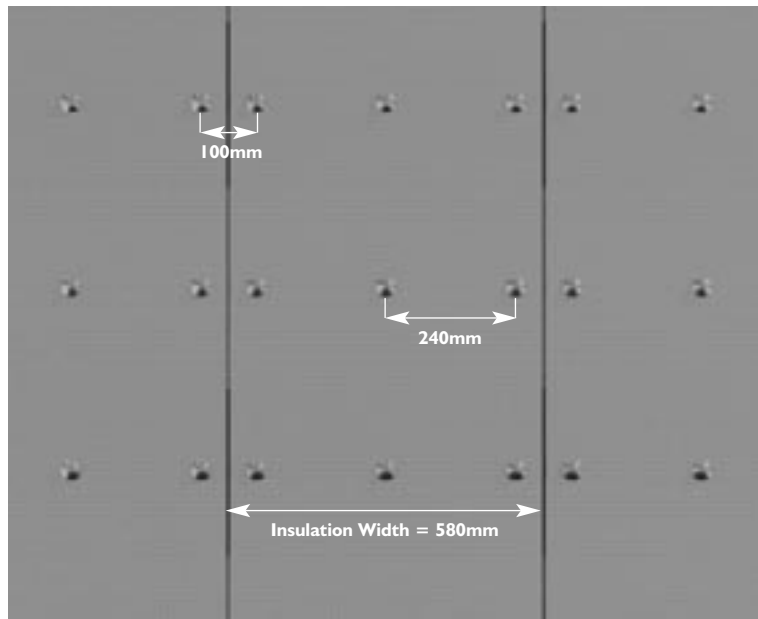

Detail of bulkhead anchor pattern (main illustration right)

NB: All illustrations shown with un-taped joints

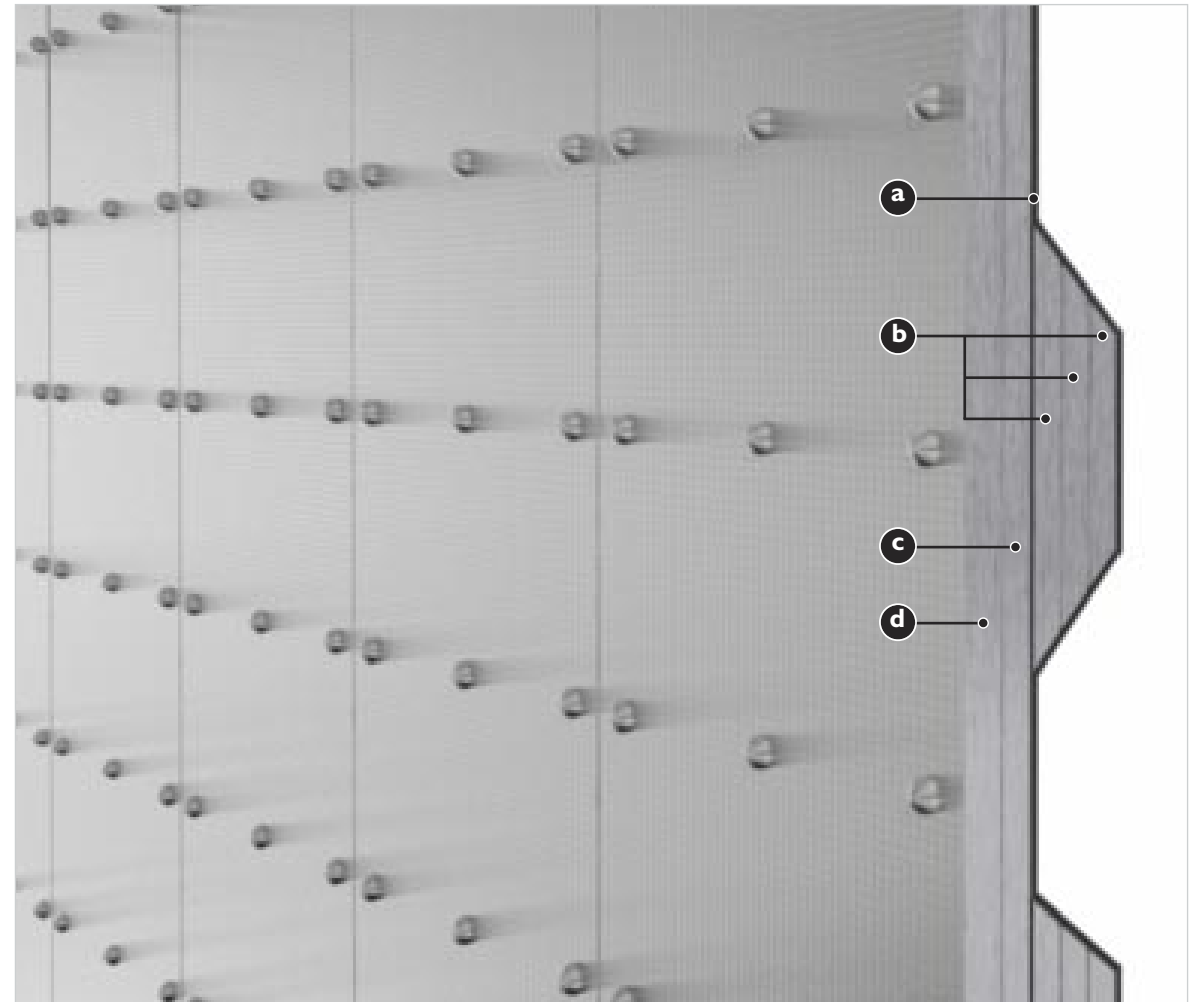

Detail of corrugated flat layer system



Jet Fire systems

Jet Fire Division

JF/120/30 and JF/180/120

Ref.	Product
a	FireMaster Marine Plus blanket 25mm x 70kg/m ³ .
b	FireMaster Marine Plus blanket 50mm x 70kg/m ³ .
c	FireMaster Marine Plus blanket 50mm x 70kg/m ³ .
d	Welded anchor pins.
e	Corrugations packed with FireMaster Marine Plus blanket 50mm x 70kg/m ³ .
f	Corrugated mild steel bulkhead 3mm thick insulated on the non-fire exposed face.

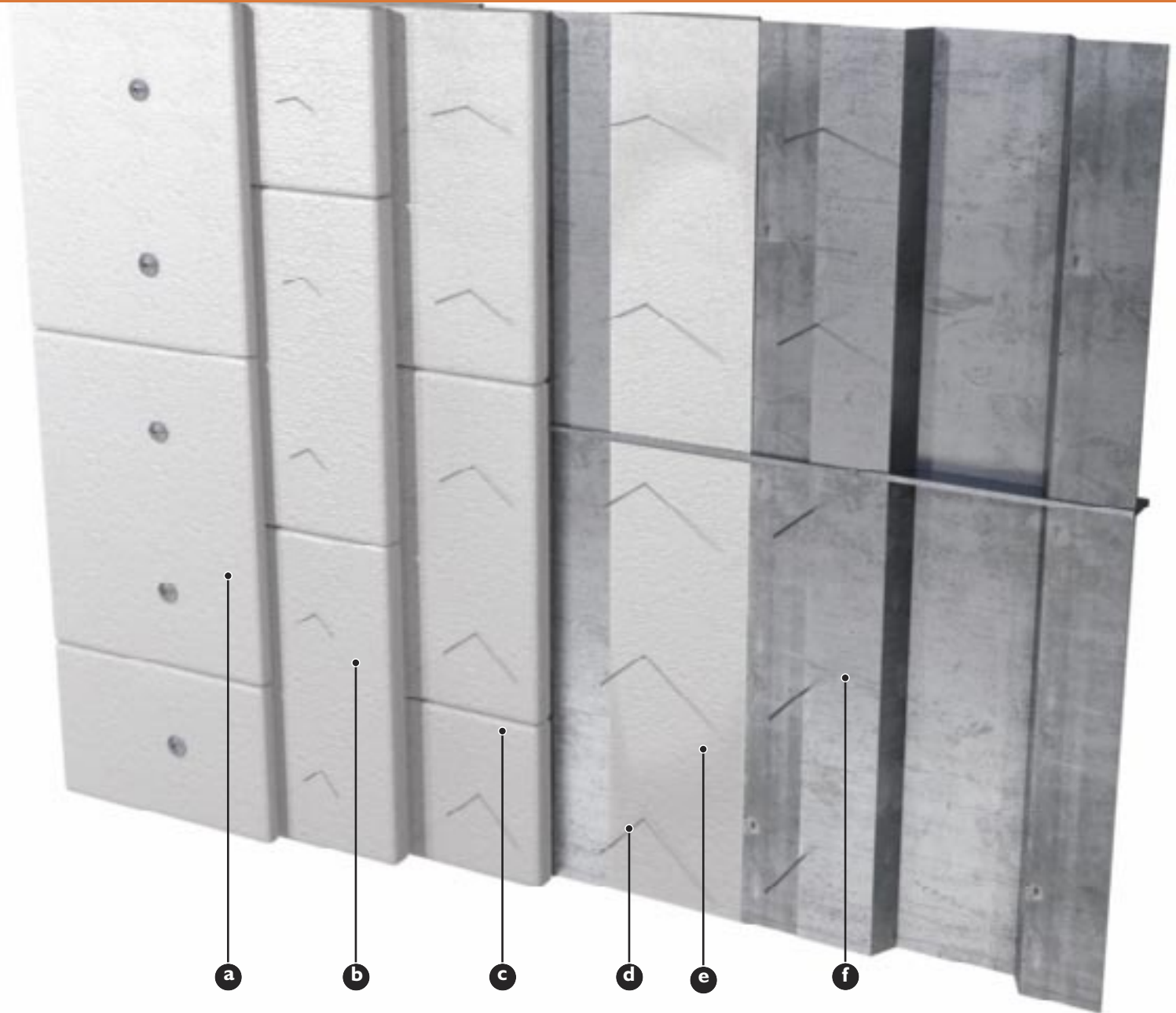

Detail views

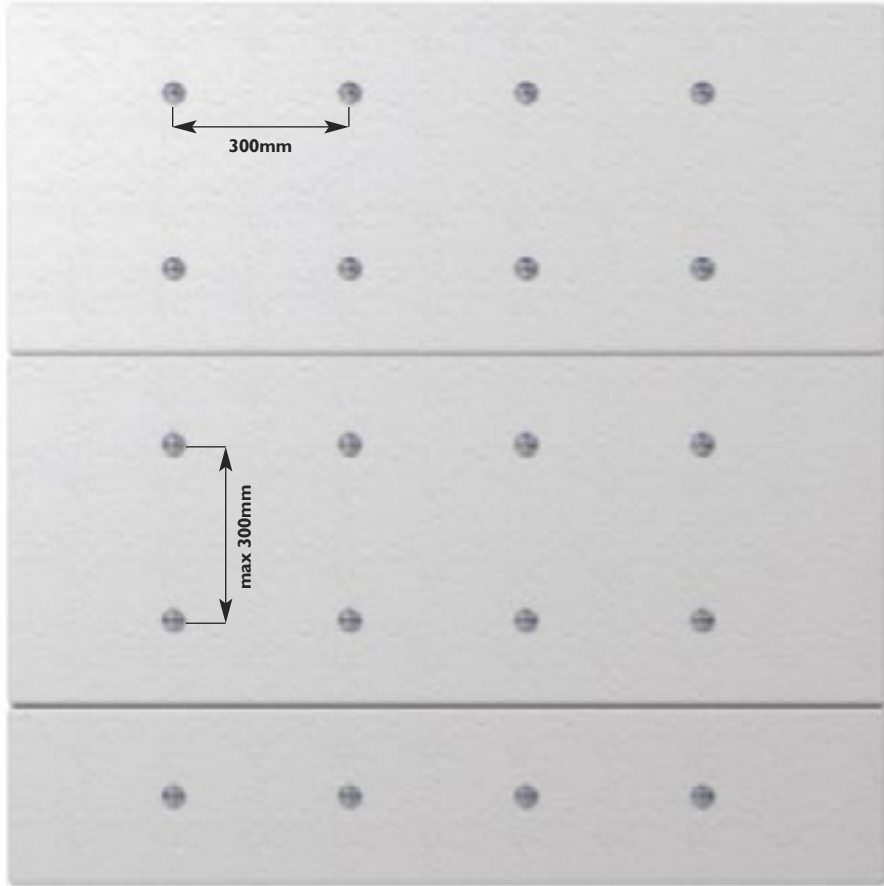

Detail of bulkhead anchor pattern

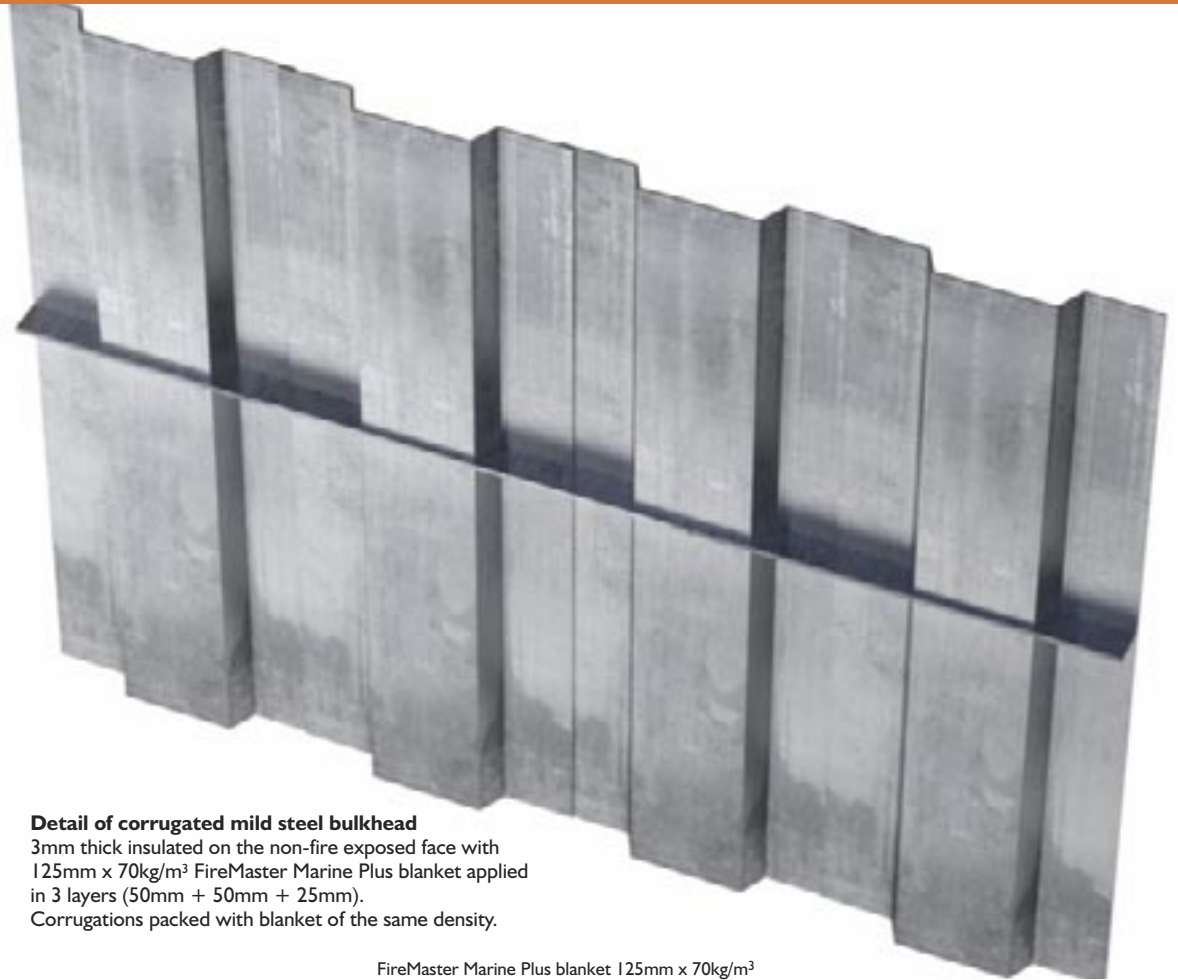

Detail of corrugated mild steel bulkhead
3mm thick insulated on the non-fire exposed face with 125mm x 70kg/m³ FireMaster Marine Plus blanket applied in 3 layers (50mm + 50mm + 25mm).
Corrugations packed with blanket of the same density.

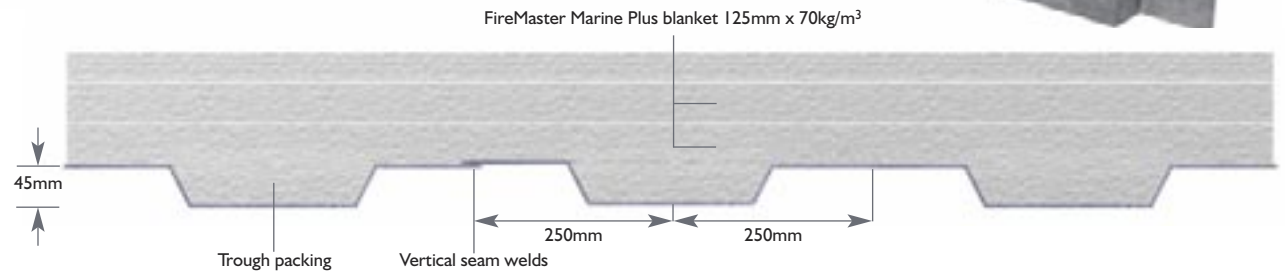

Jet Fire Division

JF/125/30 and JF/180/60



Detail of jet fire system

Ref.	Product
a	Steel bulkhead or deck.
b	Cladding spacer bars (where required) 40mm x 3mm steel approx.
c	Welded anchor pins.
d	FireMaster Marine Plus blanket 50mm x 128kg/m ³ .
e	FireMaster Marine Plus blanket 38mm x 128kg/m ³ .
f	304 grade stainless steel cladding 0.6mm thick overlapped by 75mm at edges and fixed with steel screws or rivets at 100mm centres.

System summary tables

Steel bulkheads

Fire Rating	Product	Between Stiffeners	Weight (kg/m ²)	Around Stiffeners	Weight (kg/m ²)
A15 Bulkhead	FireMaster Marine Plus blanket	25mm x 64kg/m ³ in single layer	1.6	25mm x 64kg/m ³ in single layer	1.6
A30 Bulkhead	FireMaster Marine Plus blanket	45mm x 64kg/m ³ in single layer	2.88	45mm x 64kg/m ³ in single layer	2.88
A60 Bulkhead	FireMaster Marine Plus blanket	75mm x 64kg/m ³ (45mm + 30mm)	4.8	25mm x 64kg/m ³ in single layer	1.6
A60 Bulkhead	FireMaster Marine Plus blanket	45mm x 128kg/m ³ in single layer	5.76	25mm x 128kg/m ³ in single layer	3.2
A60 Bulkhead	FireMaster Marine Plus blanket	60mm x 80kg/m ³ in single layer - profile wrap	4.8	60mm x 80kg/m ³ in single layer (NB: 60mm over the stiffener may be compressed to 25mm if required)	4.8
A60 Bulkhead	FireMaster Marine Plus blanket	2 x 40mm x 48kg/m ³	3.84	40mm x 48kg/m ³	1.92
A60 Corrugated Fire Wall 1.5mm stainless steel plate	FireMaster Marine Plus blanket	2 x 50mm x 48kg/m ³	4.8	50mm x 48kg/m ³ filled into corrugations	2.4
A60 Bulkhead (fire to insulated side only)	FireMaster Marine Plus blanket	45mm x 64kg/m ³ in single layer	2.88	45mm x 64kg/m ³ in single layer	2.88
A60 Bulkhead (fire to insulated side only)	FireMaster Marine Plus blanket	50mm x 48kg/m ³ in single layer	2.40	50mm x 48kg/m ³ in single layer	2.40

System summary tables

Steel decks

Fire Rating	Product	Between Stiffeners	Weight (kg/m ²)	Around Stiffeners	Weight (kg/m ²)
A15 Deck	FireMaster Marine Plus blanket	15mm x 64kg/m ³ in single layer	0.96	15mm x 64kg/m ³ in single layer	0.96
A30 Deck	FireMaster Marine Plus blanket	25mm x 64kg/m ³ in single layer	1.6	25mm x 64kg/m ³ in single layer	1.6
A60 Deck	FireMaster Marine Plus blanket	45mm x 64kg/m ³ in single layer	2.88	45mm x 64kg/m ³ in single layer	2.88
A60 Deck	FireMaster Marine Plus blanket	50mm x 48kg/m ³ in single layer	2.40	50mm x 48kg/m ³ in single layer	2.40
A60 Floating Floor	FireMaster Marine FireBarrier 135	20mm thick applied to non-stiffened top side of deck	22.95	Not applicable - system applied on top side of deck	0

System summary tables

B15 wall extension

Fire Rating	Product	Between Stiffeners	Weight (kg/m ²)	Around Stiffeners	Weight (kg/m ²)
B15 Wall Extension	FireMaster Marine Plus blanket with aluminium foil on both sides	30mm x 80kg/m ³	2.4	Not applicable	Not applicable

System summary tables

Aluminium bulkheads & decks : A-Class

Fire Rating	Product	Between Stiffeners	Weight (kg/m ²)	Around Stiffeners	Weight (kg/m ²)
A30 Deck	FireMaster Marine Plus blanket	40mm x 70kg/m ³ in single layer	2.8	40mm x 70kg/m ³ in single layer	2.8
A60 Deck	FireMaster Marine Plus blanket	50mm x 70kg/m ³ in single layer	3.5	50mm x 70kg/m ³ in single layer	3.5
A30 Bulkhead (fire to insulated side only)	FireMaster Marine Plus blanket	40mm x 70kg/m ³ in single layer	2.8	40mm x 70kg/m ³ in single layer	2.8
A60 Bulkhead (fire to insulated side only)	FireMaster Marine Plus blanket	50mm x 70kg/m ³ in single layer	3.5	50mm x 70kg/m ³ in single layer	3.5
A60 Bulkhead (fire either side)	FireMaster Marine Plus blanket	50mm x 70kg/m ³ in single layer applied on both sides of the bulkhead	7.0	50mm x 70kg/m ³ in single layer	3.5

System summary tables

Aluminium bulkheads & decks : HSC Code

Fire Rating	Product	Between Stiffeners	Weight (kg/m ²)	Around Stiffeners	Weight (kg/m ²)
30 minute HSC Code Deck : 2mm thick plate	FireMaster Marine Plus blanket	35mm x 70kg/m ³ in single layer	2.45	35mm x 70kg/m ³ in single layer	2.45
60 minute HSC Code Deck : 2mm thick plate	FireMaster Marine Plus blanket	50mm x 70kg/m ³ in single layer	3.5	50mm x 70kg/m ³ in single layer	3.5
30 minute HSC Code Bulkhead : 2mm thick plate	FireMaster Marine Plus blanket	35mm x 70kg/m ³ in single layer	2.45	35mm x 70kg/m ³ in single layer	2.45
60 minute HSC Code Bulkhead : 2mm thick plate	FireMaster Marine Plus blanket	50mm x 70kg/m ³ in single layer	3.5	50mm x 70kg/m ³ in single layer	3.5

System summary tables

Composite divisions - bulkheads & decks : HSC Code

Fire Rating	Product	Between Stiffeners	Weight (kg/m ²)	Around Stiffeners	Weight (kg/m ²)
30 minute HSC Code Bulkhead (fire to insulated side only)	FireMaster Marine Plus blanket	60mm x 64kg/m ³ in single layer	3.84	Not applicable	0
60 minute HSC Code Bulkhead (fire to insulated side only)	FireMaster Marine Plus blanket	3 x 25mm x 70kg/m ³ + 1 x 25mm x 64kg/m ³	6.85	Not applicable	0
30 minute HSC Code Deck (fire to insulated side only)	FireMaster Marine Plus blanket	60mm x 64kg/m ³ in single layer	3.84	1 x 60mm x 64kg/m ³ + 1 x 25mm x 64kg/m ³	4.8
60 minute HSC Code Deck (fire to insulated side only)	FireMaster Marine Plus blanket	3 x 25mm x 70kg/m ³ + 1 x 25mm x 64kg/m ³	6.85	3 x 25mm x 70kg/m ³ + 1 x 25mm x 64kg/m ³	6.85

System summary tables

H-Class bulkheads & decks

Fire Rating	Product	Between Stiffeners	Weight (kg/m ²)	Around Stiffeners	Weight (kg/m ²)
H0 Bulkhead (fire to insulated side only)	FireMaster Marine Plus blanket	40mm x 70kg/m ³	2.8	40mm x 70kg/m ³	2.8
H0 Deck	FireMaster Marine Plus blanket	40mm x 70kg/m ³	2.8	40mm x 70kg/m ³	2.8
H60 Deck	FireMaster Marine Plus blanket	2 x 40mm x 70kg/m ³	5.6	2 x 40mm x 70kg/m ³	5.6
H60 Bulkhead (fire either side)	FireMaster Marine Plus blanket	1 x 50mm + 2 x 40mm x 70kg/m ³	9.1	2 x 40mm x 70kg/m ³	5.6
H60 Bulkhead (fire to insulated side only)	FireMaster Marine Plus blanket	2 x 40mm x 70kg/m ³	5.6	2 x 40mm x 70kg/m ³	5.6
H120 Bulkhead (fire either side)	FireMaster Marine Plus blanket	3 x 50mm x 70kg/m ³	10.5	2 x 50mm x 70kg/m ³	7.0
H120 Deck	FireMaster Marine Plus blanket	1 x 50mm + 1 x 60mm x 70kg/m ³	7.7	1 x 50mm + 1 x 60mm x 70kg/m ³	7.7

Corrugated plate bulkheads

Fire Rating	Product	Between Stiffeners	Weight (kg/m ²)	Around Stiffeners	Weight (kg/m ²)
H60 and H120 Corrugated Firewall (2mm thick steel fire to either side)	FireMaster Marine Plus blanket	60mm + 50mm (total 110mm) x 70kg/m ³	7.7	3 x 50mm x 70kg/m ³	10.5

System summary tables

Jet Fire (JF) Class Fire Divisions

Fire Rating	Product	Between Stiffeners	Weight (kg/m ²)	Around Stiffeners	Weight (kg/m ²)
JF/125/30 JF/180/60 Fire Division (Deck or Bulkhead) 10mm steel plate per ISO 22899-1 standard	FireMaster Marine Plus blanket	88mm x 128kg/m ³ (50mm + 30mm)	11.3	Not applicable	-
JF/120/30 JF/180/120 Corrugated Fire Wall 3mm mild steel	FireMaster Marine Plus blanket	125mm x 70kg/m ³ (50mm + 50mm + 25mm)	8.75	Corrugations filled with blanket (40mm depth)	3.5



FIREMASTER®



System design and installation

Anchoring

System features

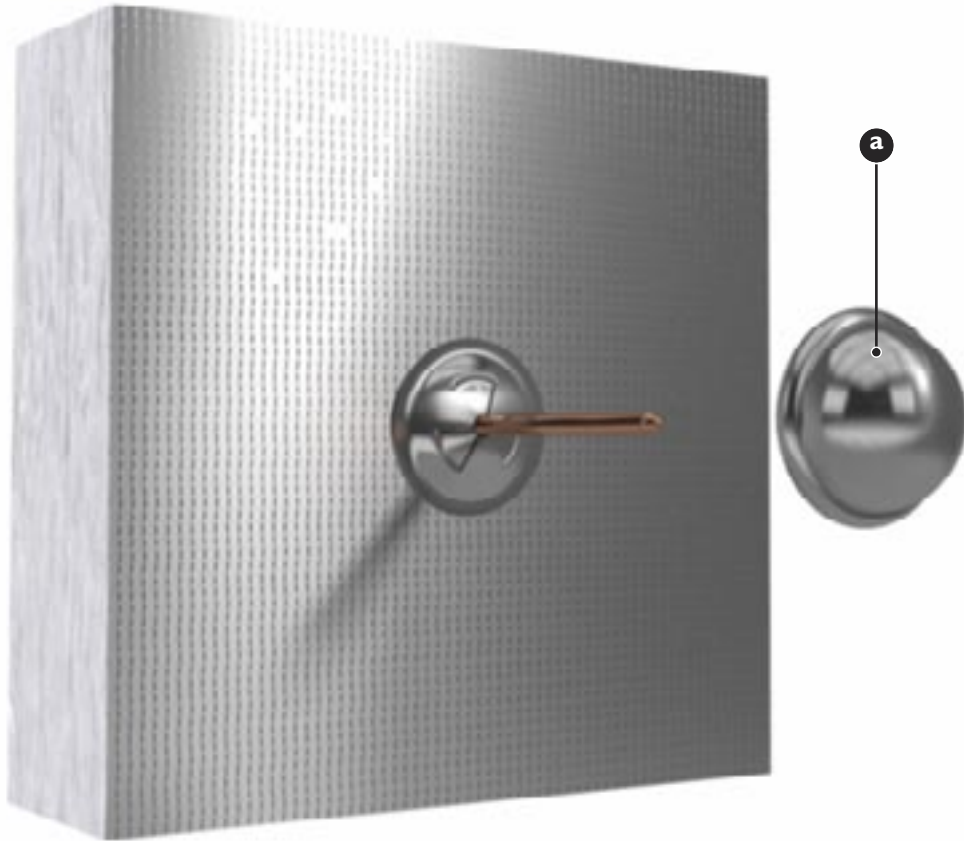

Ref.	System feature
a	Standard anchoring with or without protective caps.
b	Compression at anchor point, up to 20% possible (proven in fire tests).



Flexible blanket profile wrap

System features

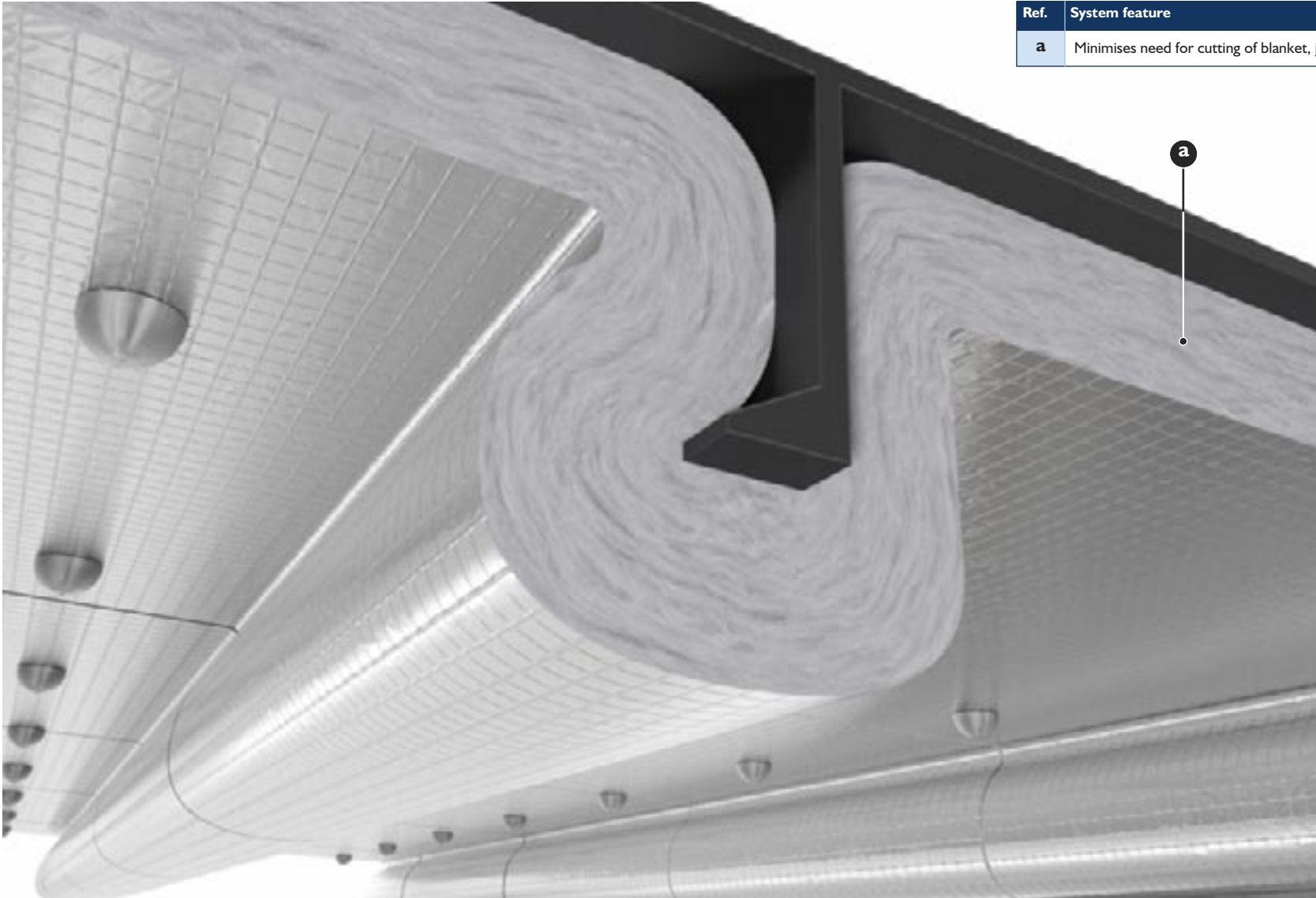

Ref.	System feature
a	Minimises need for cutting of blanket, joints or anchors on stiffeners.

Large beam insulation options

System features

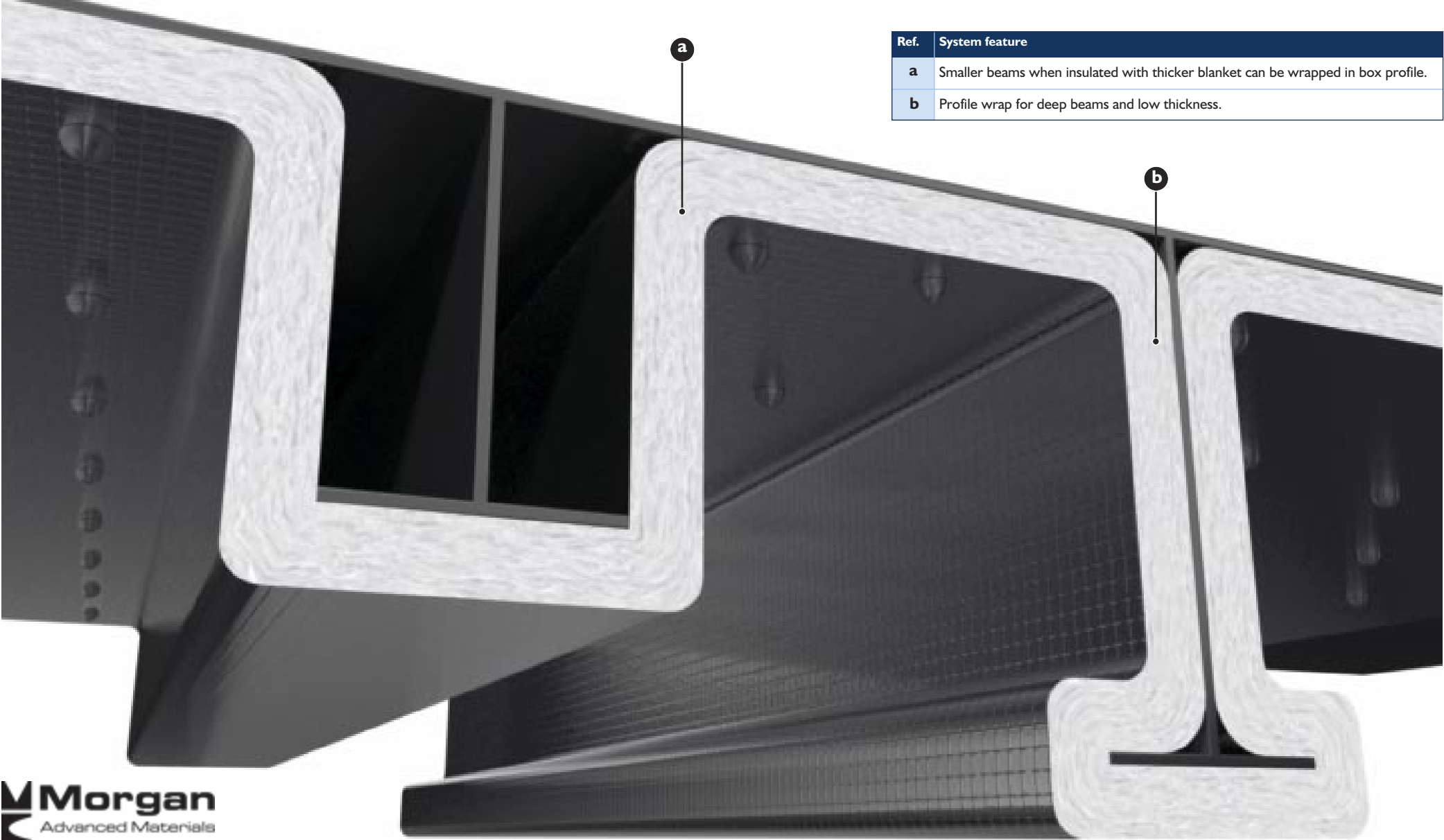

Ref.	System feature
a	Smaller beams when insulated with thicker blanket can be wrapped in box profile.
b	Profile wrap for deep beams and low thickness.

Taped joints

System features



Ref.	System feature
a	Minimum wastage, less joints : less sealing tape.

Insulation to avoid heat bridging

Guidance on the methods for extending insulation to avoid heat bridging

Stiffeners longer than 450mm

IMO MSC 1120 Section 9.3.4 gives guidance on the methods for extending insulation to avoid heat bridging. The fire insulation is installed over stiffeners following the normal installation technique where the stiffener length is less than 450mm.

Where stiffeners are longer than 450mm the insulation is terminated at 450mm as illustrated, opposite.

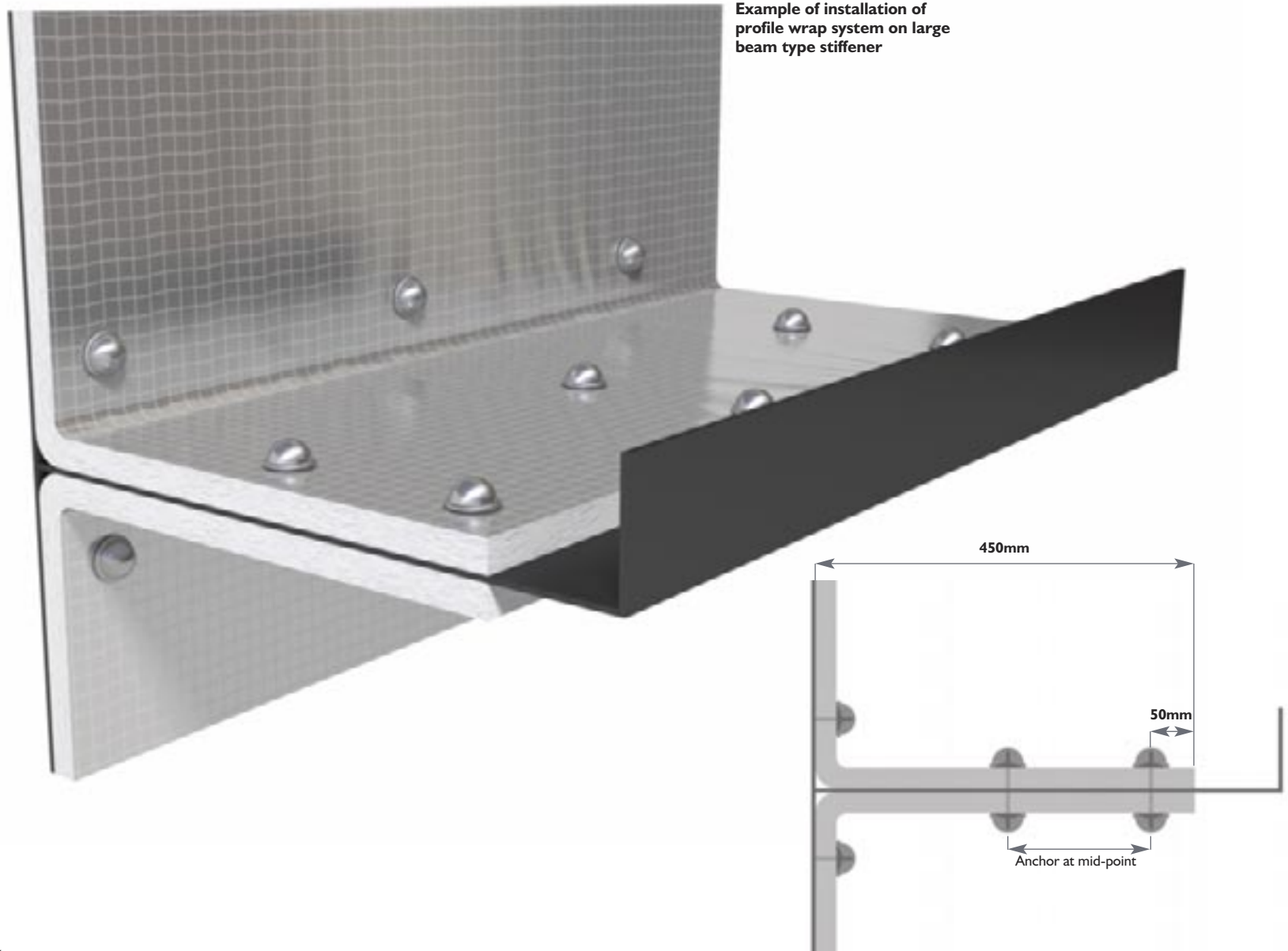

Insulation to avoid heat bridging

Guidance on the methods for extending insulation to avoid heat bridging

Insulation extending onto adjacent bulkheads or decks

IMO MSC 1120 Section 9.3.4.

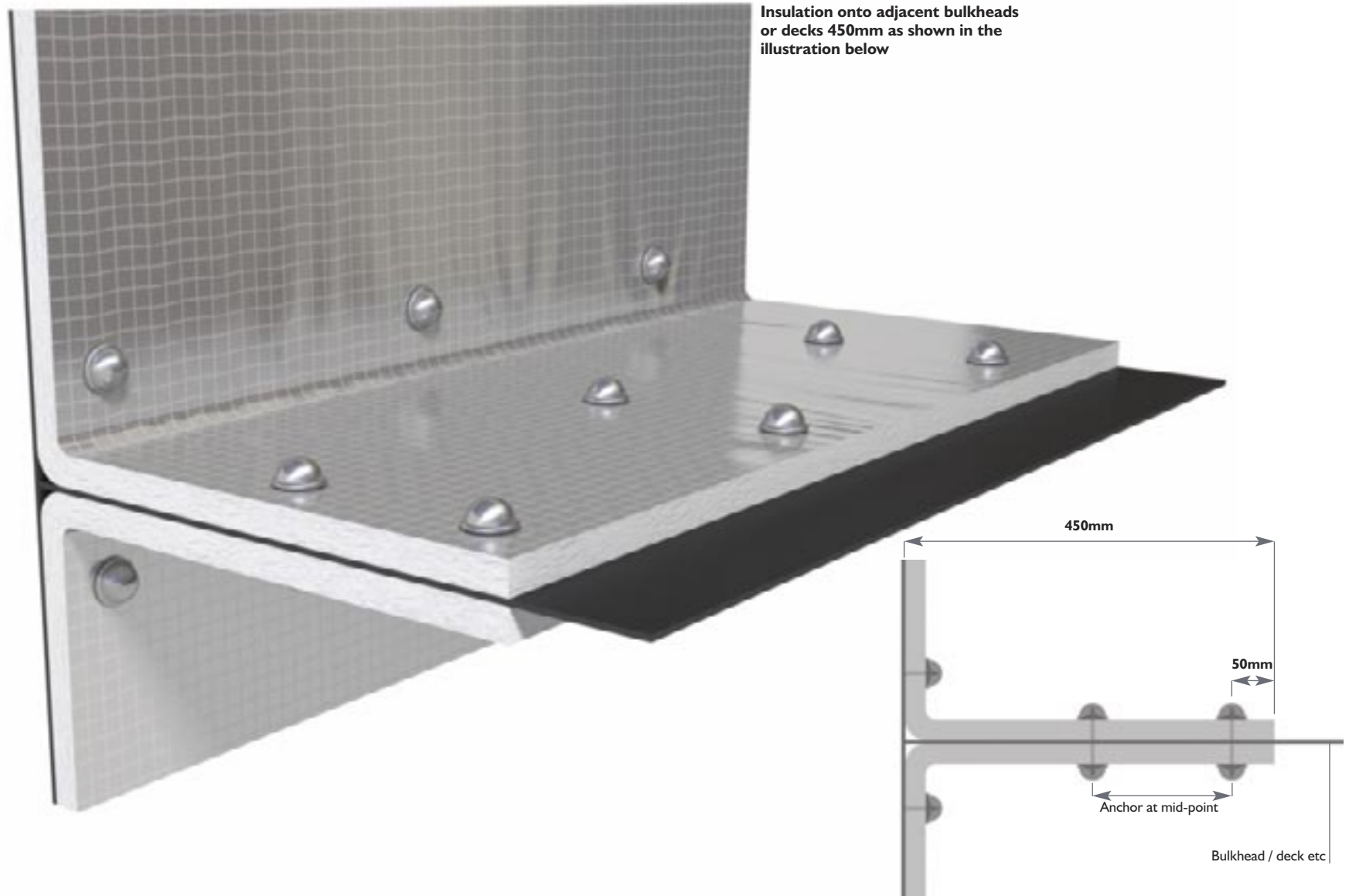

Insulation to avoid heat bridging

Guidance on the methods for extending insulation to avoid heat bridging

Alternative arrangement of insulation to avoid heat bridging

IMO MSC 1120 Section 9.3.4.

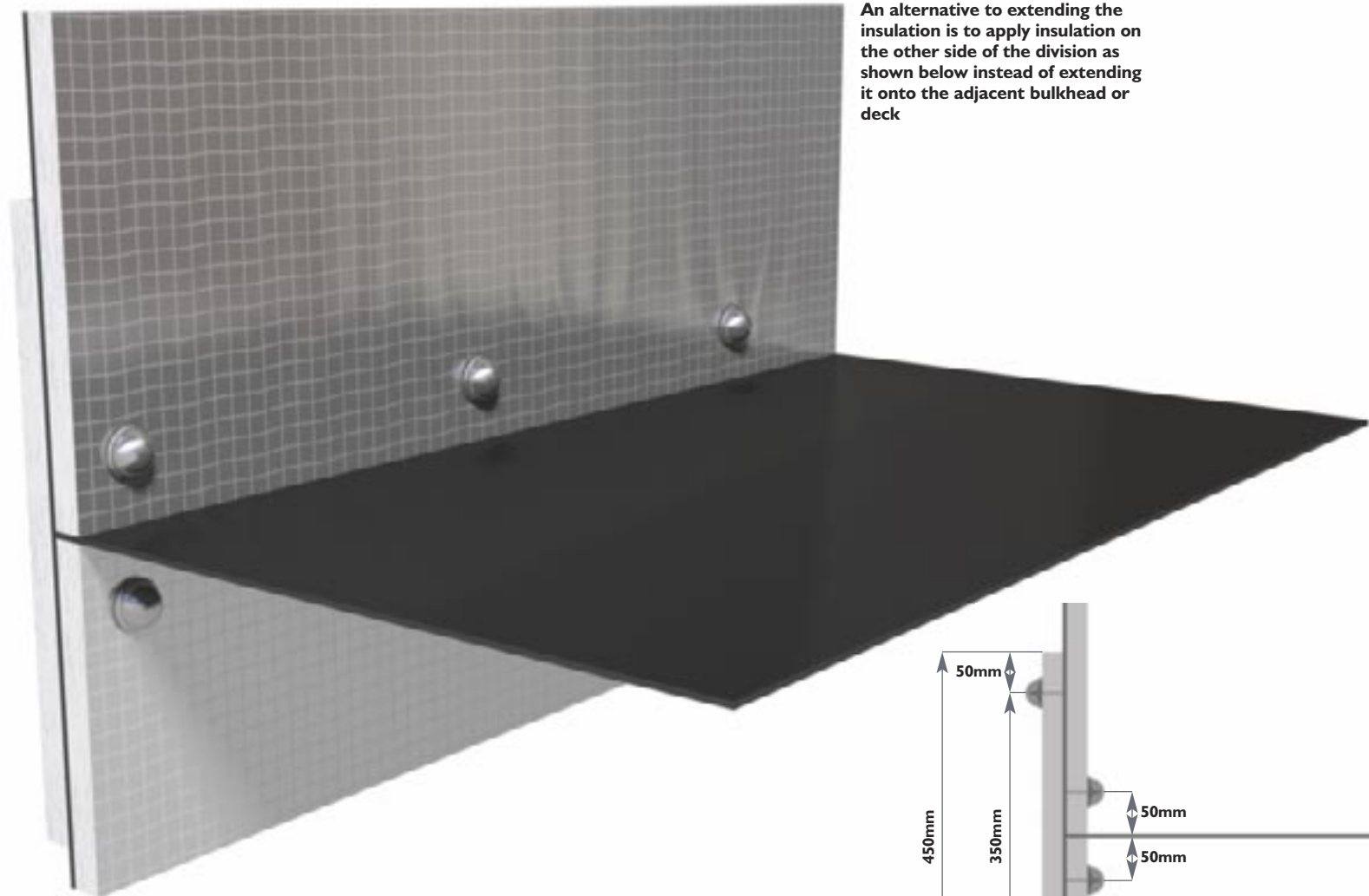

An alternative to extending the insulation is to apply insulation on the other side of the division as shown below instead of extending it onto the adjacent bulkhead or deck

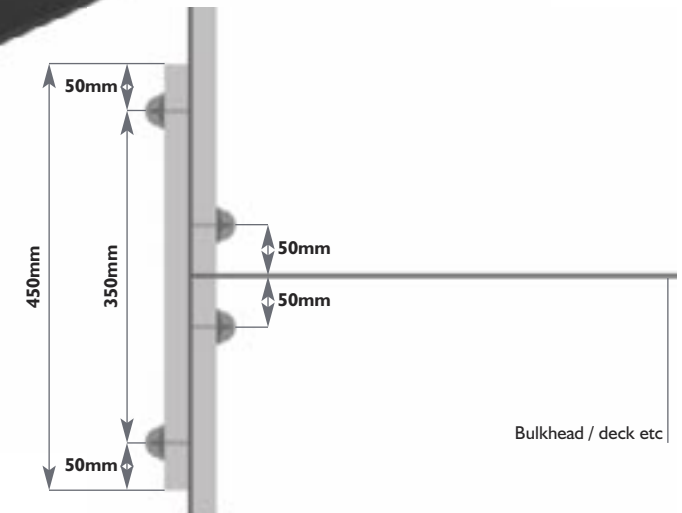

Insulation to avoid heat bridging

Guidance on the methods for extending insulation to avoid heat bridging

Insulation onto fire division with lower fire rating

According to SOLAS II-2 9 Section 3.4, if a space is divided with a deck or a bulkhead of A-Class standard having insulation of different values, the insulation with the higher value shall continue on the deck or bulkhead with the insulation of the lesser value for a distance of at least 450mm. The drawing, right, gives an example of recommended installation for an A60 division connected to an A30 division.

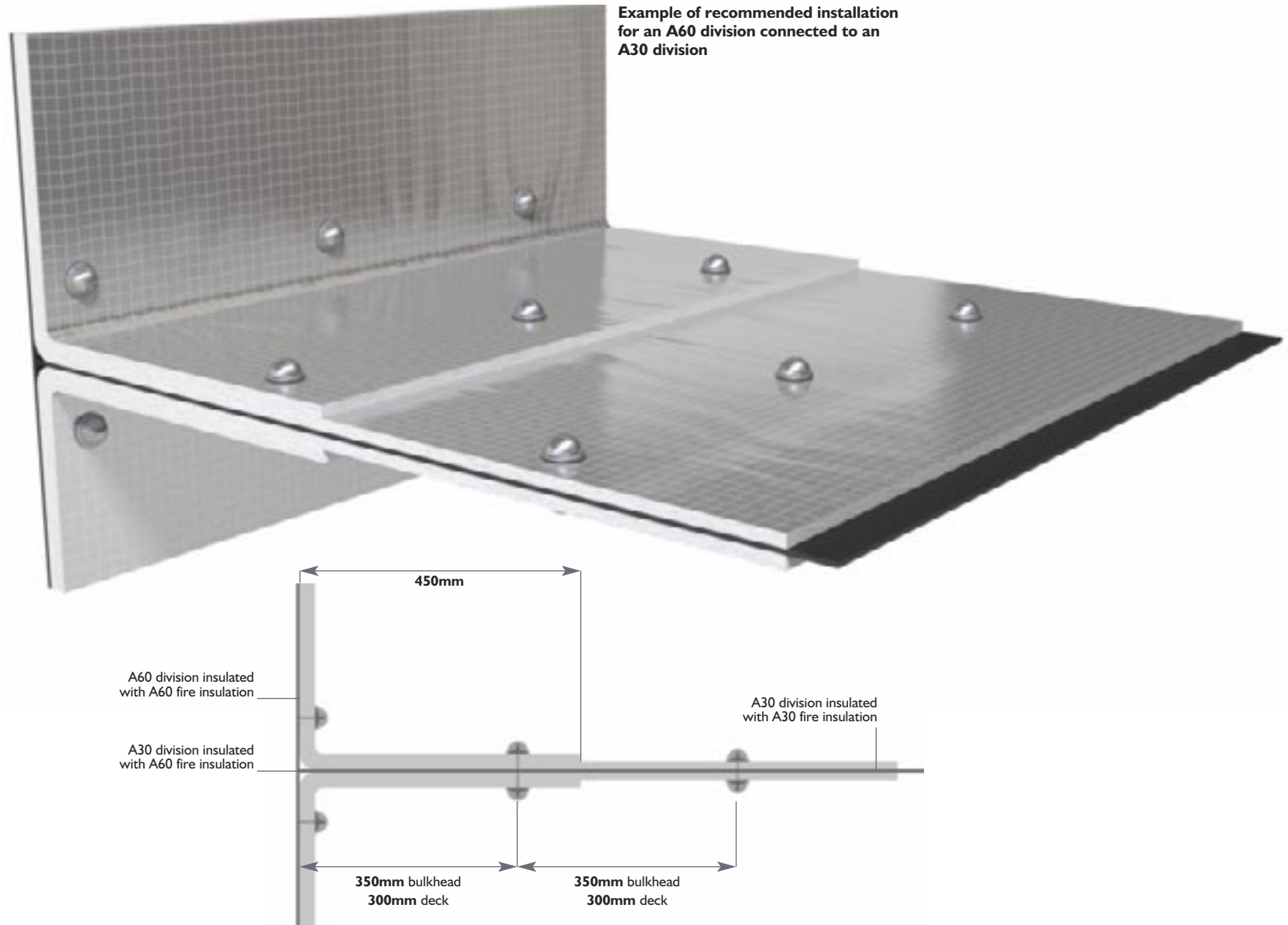

Stiffeners

Profile wrap installation methods

Adapting the system to different sizes

The Profile wrap system is easy to adapt to different stiffener sizes as the FireMaster blanket follows the contour of the structure and the same thickness of insulation is installed over stiffeners as is applied on the flat plate.

This means different shaped (e.g. 'bulb-flat') or different sized stiffeners can be wrapped in the same general manner as the fire-tested system.

Where very large structural sections have to be insulated, additional anchors are recommended to provide support to the blanket.

On large beams or stiffeners anchors are added where the unsupported blanket length would be more than 300mm as shown opposite.

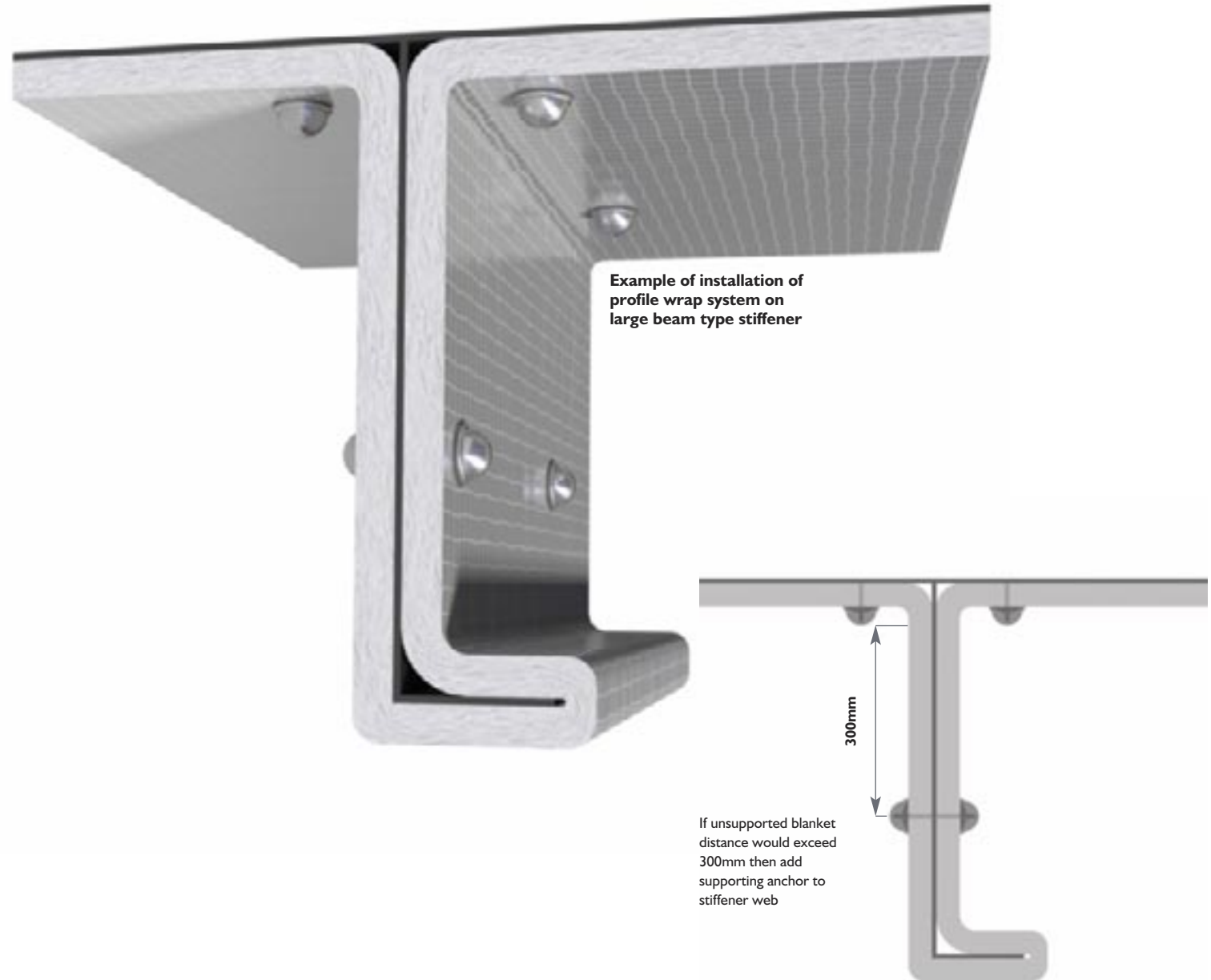

Stiffeners

Profile wrap installation methods

To avoid slumping or sagging of the FireMaster blanket when fitting the profile wrap system around stiffeners, an anchor may be added to the underside of the stiffener to provide extra support.

The maximum unsupported blanket length should not exceed 600mm when fitted around stiffeners as shown opposite.



Example of anchor fixing to avoid slumping or sagging

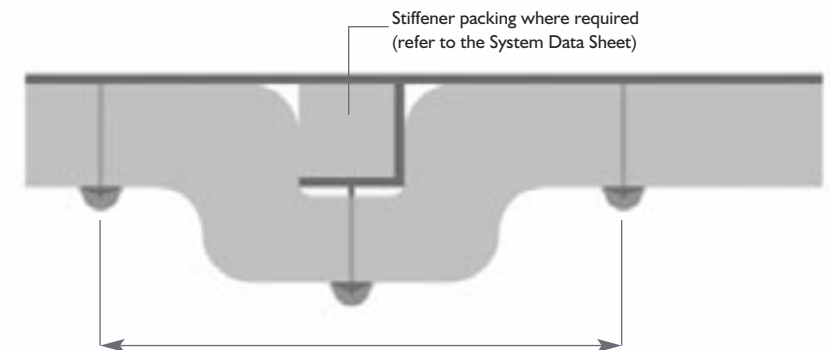

If maximum unsupported blanket distance >600mm then add anchor to underside of stiffener

Stiffeners

Bulkheads where stiffeners use thinner insulation than the bulkhead plate

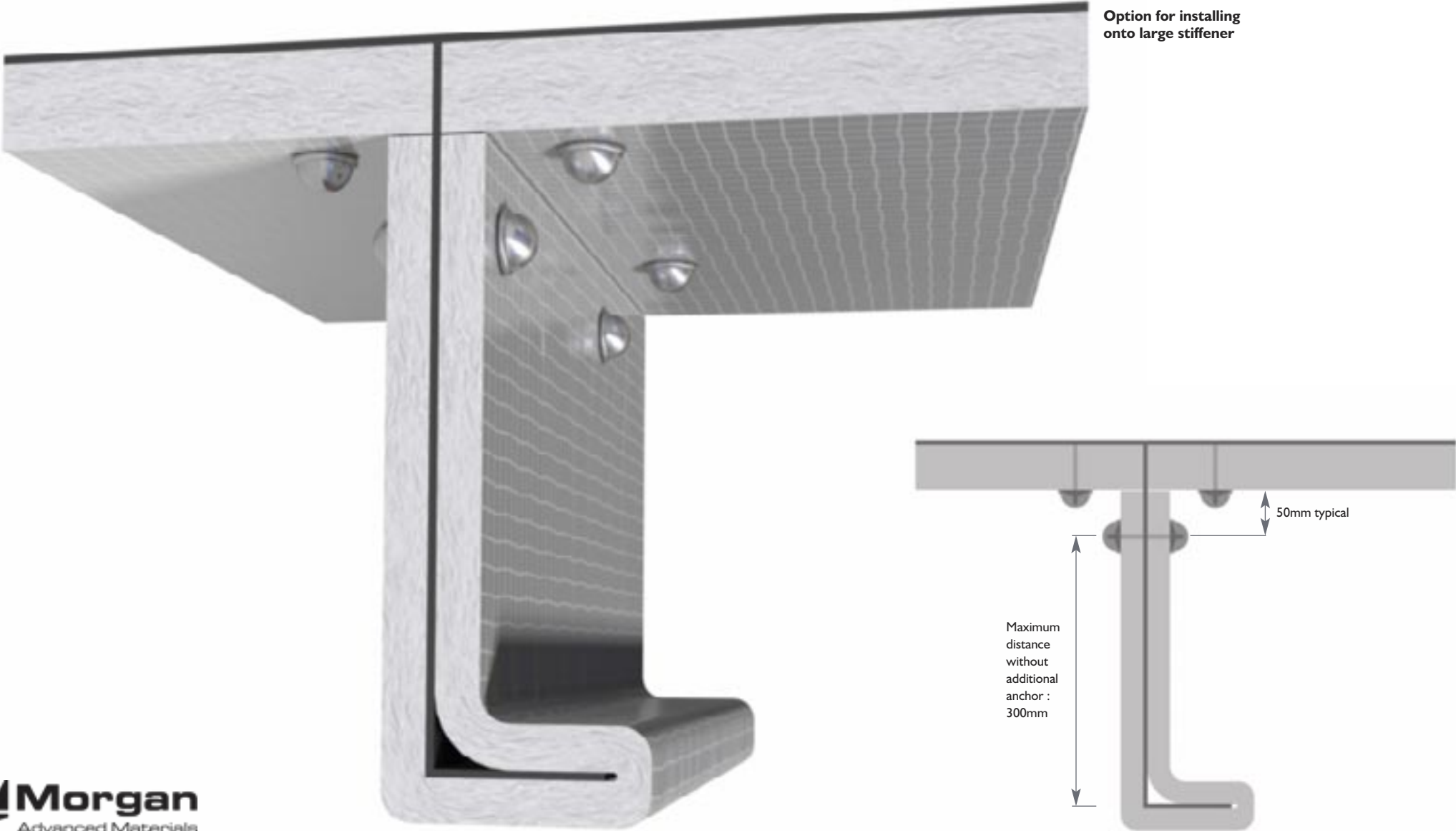

Large beams

Bulkheads where stiffeners use thinner insulation than the bulkhead plate

For some bulkhead systems the stiffeners are insulated with a different thickness of FireMaster blanket than that installed on the main bulkhead plate.

In this case the installation of the blanket can be carried out in one of the ways shown in the illustrations opposite and on page 90.

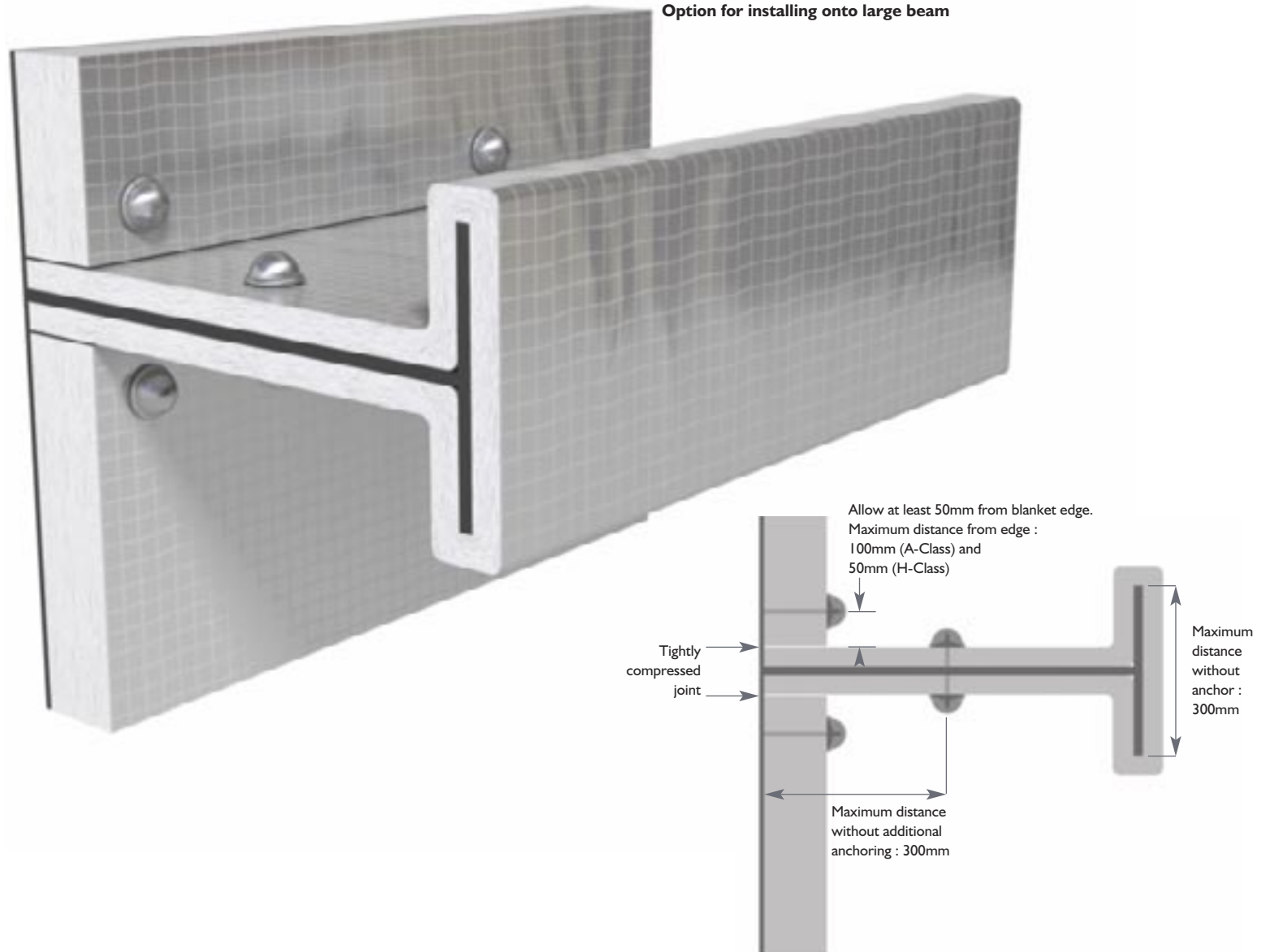

Large beams

Bulkheads where stiffeners use thinner insulation than the bulkhead plate

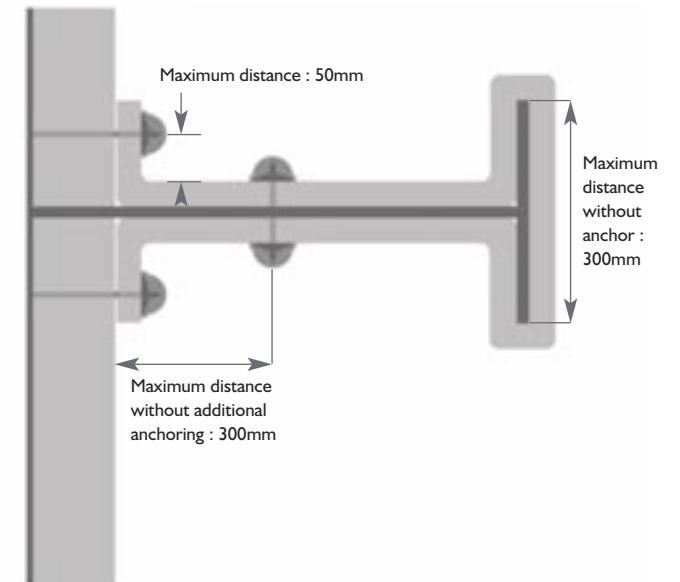
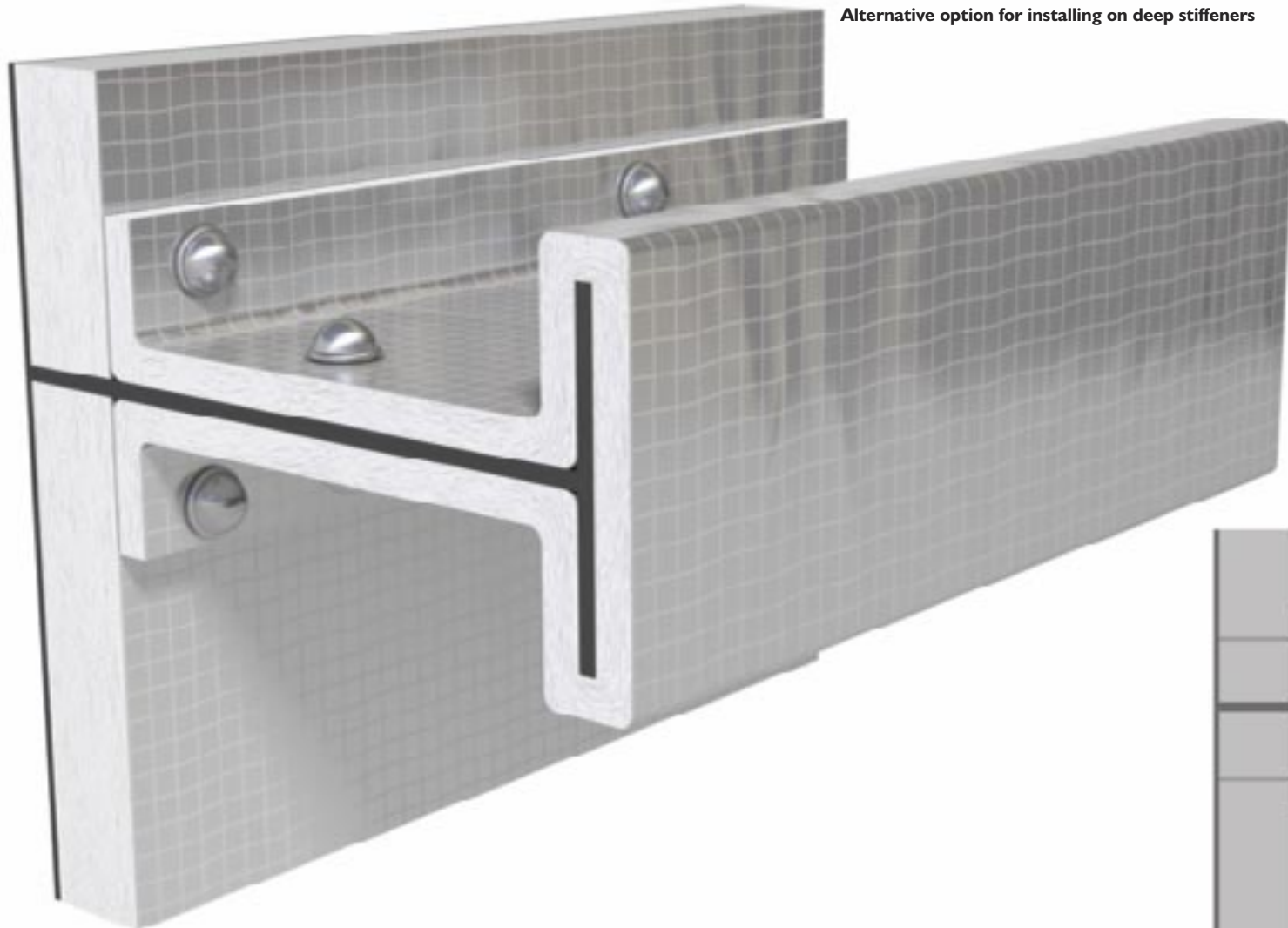

Penetration sealing

Penetration sealing

SOLAS II-2 Regulation 9, 'Containment of fire' Section 3 'Penetrations in fire - resisting divisions and prevention of heat transmission' has specific guidance on the treatment of penetrations through fire divisions.

According to section 3, where A-Class divisions are penetrated, such penetrations shall be tested in accordance with the Fire Test Procedures Code.

However, where a pipe penetration is made of steel or equivalent material having a thickness of 3mm or greater and a length of not less than 900mm (preferably 450mm on each side of the division), and there are no openings, testing is not required.

Such penetrations shall be suitably insulated by extension of the insulation at the same level of the division as illustrated opposite.

According to section 3.4, the insulation of a deck or bulkhead shall be carried past the penetration, intersection or terminal point for a distance of at least 450mm in the case of steel and aluminium structures.

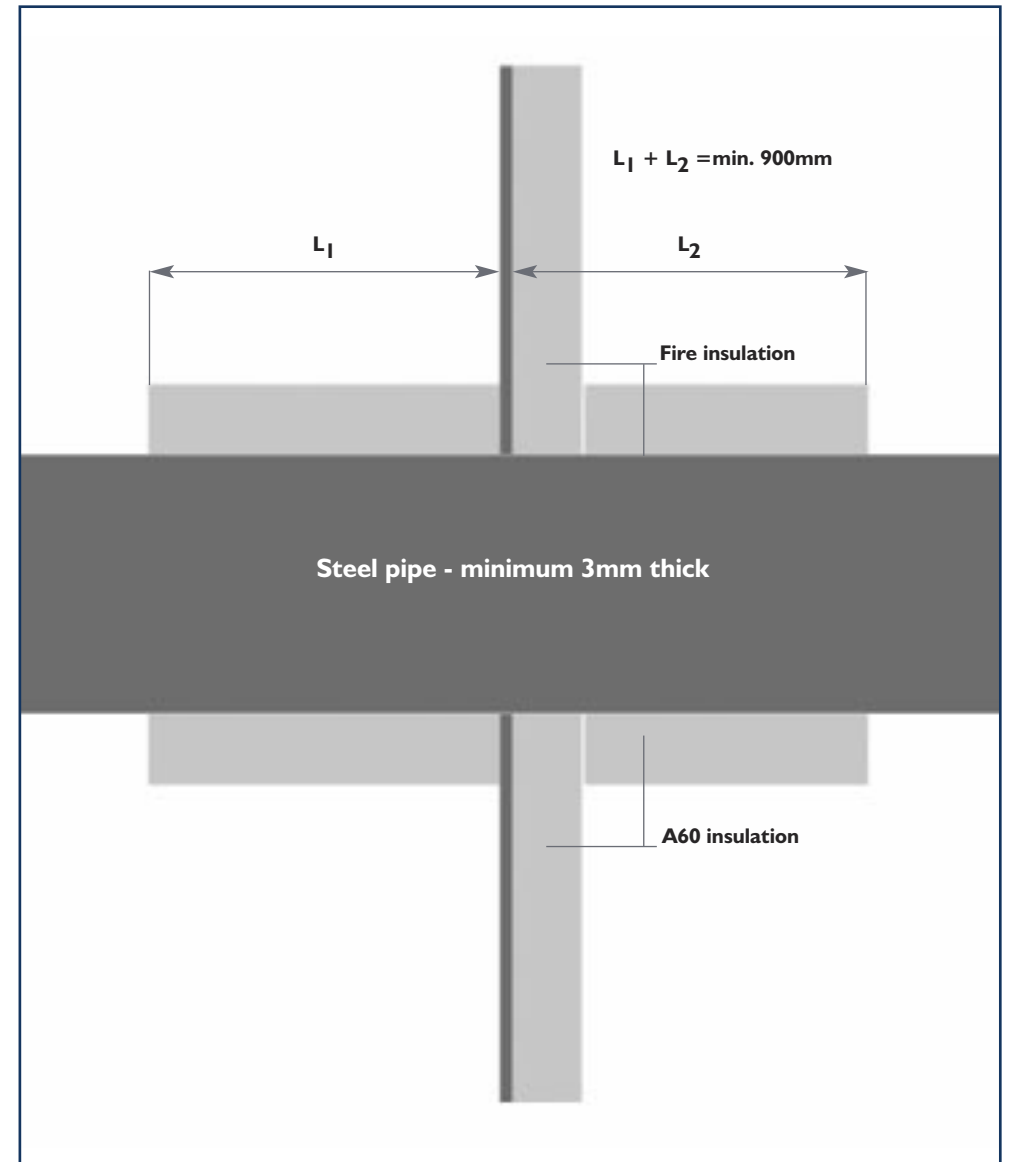



FIREMASTER[®]



Thermal insulation of bulkheads and decks

Thermal insulation of bulkheads and decks

Thermal insulation performance of bulkheads and decks is normally expressed as an overall 'U-value' for the entire structure. The U-value can be used in calculations of total heat loss from a bulkhead or deck where the amount of heat loss of the structure is a function of its surface area, temperature gradient and overall U-value. Methodologies for calculating the heat loss of marine accommodation areas are given in ISO 7547-2002 standard. The overall U-value of a structure is a combination of the R values of each individual component and the surface heat transfer coefficients.

The R-value for an insulation material is calculated using its thermal conductivity measured at a standard temperature of 10°C.

These three values may be defined as follows:

Thermal Conductivity (Lambda or K-value)

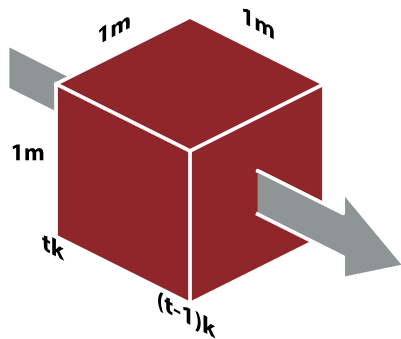

$$\lambda = W/mK$$

Thermal conductivity (often referred to as the 'lambda' (λ) or 'K'-value) is a measure of how well a material conducts heat.

Thermal conductivity is the quantity of heat (W), which is conducted through 1 m² in a thickness of 1 m, when the difference in temperature between the opposite surfaces equals 1 K (or 1°C). In practice thermal conductivity is a numerical value expressed in terms of W/mK.

The lower the thermal conductivity value, the better the insulation property of the material. Note that thermal conductivity for insulation materials generally increases significantly with increasing temperature.

Examples of thermal conductivity of various materials at 10°C

Steel	: 50	W/mK
Concrete	: 1.6	W/mK
Glass	: 1.1	W/mK
Wood	: 0.12	W/mK
Mineral Wool 100kg/m³	: 0.035	W/mK
FireMaster Marine Plus blanket 48kg/m³	: 0.0321	W/mK

R-value

Thermal resistance, 'R', is a measure of the insulation value of a specified thickness of an insulation material. It is simply the insulation thickness divided by its thermal conductivity value.

The higher the R-value, the better the insulation.

U-value

Thermal Transmittance Coefficient or U-value represents the flow of heat through a structure. The U-value is the flow of heat (in W) through 1 m² of a structure when the difference between the two surrounding temperatures is 1 K (or 1°C). It is expressed as: W/(m²K).

The lower the U-value, the better the insulation value of the structure.

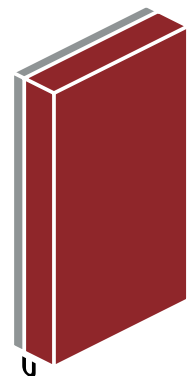

$$U = W/m^2K$$

Thermal insulation of bulkheads and decks

Relationship between Thermal conductivity, R-value and U-value:

$$\text{R-VALUE (m}^2\text{K/W)} = \frac{\text{Thickness (m)}}{\text{Thermal conductivity (W/mK)}}$$

$$\text{U-VALUE (W/m}^2\text{K)} = \frac{1}{\text{(R-value)}}$$

FireMaster Marine Plus blanket U-values and R-values

R-values (m² K/W) and corresponding U-values (W/m²K) for various FireMaster Marine Plus blanket thicknesses are given in the table opposite.

When using densities above 64kg/m³, the values for 64kg/m³ may be taken as applicable as the thermal conductivity decreases with increasing density for the range of FireMaster Marine Plus blanket densities. Therefore, U and R-values will be better than the values calculated using thermal conductivity data for 64kg/m³.

Thickness of blanket	48kg/m ³		64kg/m ³	
	R-value	U-value	R-value	U-value
25mm	0.78	1.28	0.78	1.28
30mm	0.93	1.07	0.94	1.06
35mm	1.09	0.92	1.10	0.91
40mm	1.25	0.80	1.25	0.80
45mm	1.40	0.71	1.41	0.71
50mm	1.56	0.64	1.57	0.64
60mm	1.87	0.54	1.88	0.53
70mm	2.18	0.46	2.19	0.46
75mm	2.34	0.43	2.35	0.43
80mm	2.49	0.40	2.51	0.40
90mm	2.80	0.36	2.82	0.35
100mm	3.12	0.32	3.13	0.32
110mm	3.43	0.29	3.45	0.29
120mm	3.74	0.27	3.76	0.27
130mm	4.05	0.25	4.08	0.25
150mm	4.67	0.21	4.70	0.21

Basis of calculation: Thermal conductivity of FireMaster Marine Plus blanket measured at 10°C to BS EN 12667 method : 0.0319 W/mK (64kg/m³ density), 0.0321 W/mK (48kg/m³ density).



FIREMASTER[®]



Acoustic insulation of bulkheads and decks

Acoustic insulation of bulkheads and decks

The acoustic insulation properties of insulation materials are usually expressed in terms of sound absorption or sound reduction/sound transmission loss. Another material property, airflow resistance, is also sometimes used in calculations of acoustic insulation performance.

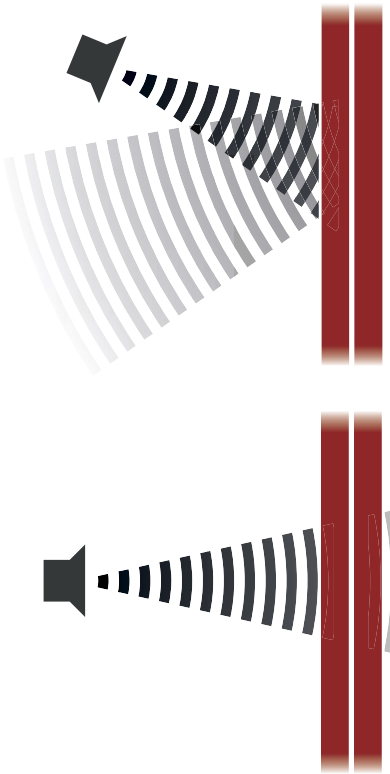

Sound absorption

Sound absorption is a material property which describes how well sound waves are absorbed in a material. When a sound wave is absorbed, it simply means that the sound wave is transferred into another kind of energy i.e. heat.

For acoustic insulation requirements, sound absorption is relevant when considering noise levels within the same space as the noise source. The ability of the walls, floor and roof of a room to absorb noise will be important in reducing noise reflected back into the room from the surfaces of its boundaries.

Sound reduction / sound transmission loss

Sound reduction values are specific to constructions rather than a material property. The sound reduction value specifies the reduction of sound through an element of construction (wall, floor, or roof). For acoustic insulation requirements, the sound reduction value is relevant when considering noise levels in a space that is separate from the noise source, for example adjacent rooms separated by a wall. Sound reduction values for any construction will vary with the frequency of the sound source. Although sound reduction values for a construction are measured at various frequencies, an overall single figure is used to express the sound reduction value.

This figure is called the 'weighted sound reduction' or 'sound transmission loss' value (R_w) and is the almost equal to the sound reduction achieved in the middle of the human hearing range. The weighting procedure is standardised in ISO 717-1 standard for the sound reduction of airborne noise.

Airflow resistance

According to ISO 9053 this is the quotient of the air pressure difference across the specimen divided by the linear velocity, measured outside the specimen, of airflow through the specimen. For a homogeneous material the quotient of the specific airflow resistance divided by its thickness is called the airflow resistivity (r). Airflow resistance is a main product property of porous materials influencing the sound absorption in the material.

Acoustic insulation of bulkheads and decks

Sound absorption

Test Method: BS EN ISO 354:2003

FireMaster Marine Plus blanket 45mm x 64kg/m³

Un-faced (no surface covering material used)

Sound absorption rating: 'Class A'

Frequency (Hz)	Sound absorption coefficient
125	0.15
250	0.75
500	1.00
1000	1.00
2000	1.00
4000	0.75
Overall sound absorption coefficient	1.00

Faced with glass cloth

Sound absorption rating: 'Class B'

Frequency (Hz)	Sound absorption coefficient
125	0.40
250	0.95
500	0.95
1000	0.85
2000	0.80
4000	0.65
Overall sound absorption coefficient	0.80

Faced with 30µm reinforced aluminium foil

Sound absorption rating: 'Class C'

Frequency (Hz)	Sound absorption coefficient
125	0.45
250	0.90
500	0.75
1000	0.65
2000	0.65
4000	0.45
Overall sound absorption coefficient	0.65

Acoustic insulation of bulkheads and decks

Sound reduction

Weighted Sound Transmission Loss (R_w) values (ISO 717-1)

Steel bulkheads insulated with FireMaster Marine Plus blanket

System Construction Details	R_w (ISO 717-1)
45mm x 64kg/m ³ FireMaster Marine Plus blanket on bulkhead plate and stiffeners	45 dB
45mm x 64kg/m ³ FireMaster Marine Plus blanket + aluminium foil on bulkhead plate – stiffeners not insulated	44 dB
45mm x 64kg/m ³ FireMaster Marine Plus blanket + aluminium foil on bulkhead plate and stiffeners	47 dB
45mm x 128kg/m ³ FireMaster Marine Plus blanket on bulkhead plate and stiffeners	46 dB
50mm x 48kg/m ³ FireMaster Marine Plus blanket + aluminium foil on bulkhead plate – stiffeners not insulated	44 dB
50mm x 48kg/m ³ FireMaster Marine Plus blanket + aluminium foil on bulkhead plate and stiffeners	47 dB
75mm x 64kg/m ³ FireMaster Marine Plus blanket + aluminium foil on bulkhead and stiffeners	49 dB
75mm x 64kg/m ³ FireMaster Marine Plus blanket + ALGC foil on bulkhead and stiffeners	50 dB
60mm x 64kg/m ³ FireMaster Marine Plus blanket + ALGC foil on bulkhead and stiffeners	47 dB
60mm x 48kg/m ³ FireMaster Marine Plus blanket + ALGC foil on bulkhead. Stiffeners not insulated	47 dB
80mm x 70kg/m ³ FireMaster Marine Plus blanket + ALGC foil on bulkhead and stiffeners	52 dB

FRP composite sandwich panel bulkhead

(1.0 to 1.4mm GRP laminate and 50mm PVC Core 80 kg/m³)

FRP composite bulkhead specified above insulated with 3 layers of 25mm

FireMaster Marine Plus blanket 70 kg/m³ plus 1 layer of 25mm

FireMaster Marine Plus blanket 64 kg/m³ all layers with aluminium foil facing: $R_w = 37$ dB

Airflow resistance

Airflow resistance of FireMaster Marine Plus blanket (ISO 9053: 1991)

Airflow Resistance of 45mm x 64 kg/m³

FireMaster Marine Plus blanket: 50.4 kPa.s/m²

Guide to specification and certification of fire divisions used in marine and offshore

Guide to the specification and performance requirements of fire divisions used in marine and offshore

Classification of fire divisions

Requirements of fire divisions

Fire divisions are used to contain fire and smoke within their boundaries. This is often described as ‘compartmentation’; fire and smoke are contained within the compartment in which the fire occurs.

A fire division should prevent the spread of smoke and flame. The fire division must maintain integrity in a fire, providing a physical barrier to fire spread. It may also need to be insulated in order to limit heat conduction across the division, to prevent the spread of fire due to ignition of materials on the surface of the non-fire exposed side.

The requirements that must be satisfied by a fire-rated bulkhead, deck or floor are defined in the International Maritime Organisation 2010 Fire Test Procedures (IMO 2010 FTP) code part 3. The test has performance requirements for integrity and insulation. Depending on the class of the fire division, insulation performance is not always required.

IMO 201 FTP code Part 3 performance requirement	Reason for the requirement	Performance to be achieved
‘Integrity’	Prevent gaps, cracks opening up in the fire division through which fire could spread.	No flaming on the non-fire exposed face of the division. No gaps above 6mm for 150mm length or any gaps above 25mm. If small gaps are present, ignition of cotton pad held over the gap should not occur.
‘Insulation’	Prevent excessive heat transmission through the division causing ignition of materials on the other side resulting in fire spread across the division.	Average temperature and maximum temperature of the unexposed face should not rise by more than a specified value. The temperature values specified depend on the class of the fire division (see opposite).

Classification of fire divisions in the IMO 2010 FTP Code Part 3 test:

A and B-Class divisions

Fire divisions are classed as A, B, or F depending on the degree of fire protection performance required. Of these classifications, only A and B are common requirements on board ships and offshore platforms etc. A and B-Class fire divisions are designated by class type and the fire insulation performance they provide.

The table below summarises the performance requirements of each type.

Fire division class	Integrity (minutes)	Insulation (minutes)
A0	60	0
A15	60	15
A30	60	30
A60	60	60
B0	30	0
B15	30	15
B30	30	30

Insulation performance, where it is required, is the time in minutes that the fire division satisfies a specified temperature rise limit on the non-fire exposed face. These limits are shown in the table below.

Temperature rise limits for fire divisions for ‘Insulation’ criterion of fire test

Division class	Average temperature rise allowed in fire test	Maximum temperature rise allowed in fire test
A	140°C	180°C
B	140°C	225°C
F	140°C	225°C

All A-Class divisions require integrity for a full 60 minutes. This can be achieved without insulation if the division is constructed from steel but where materials of construction other than steel are used; there is a requirement to add insulation to achieve 60 minutes integrity. This is discussed in more detail further in this section.

Guide to the specification and performance requirements of fire divisions used in marine and offshore

Classification of fire divisions

Classification requirements for H-Class divisions

The IMO FTP code specifies a temperature/time fire curve relationship used for the fire testing of A and B-Class divisions. This fire curve is derived from the combustion of cellulosic materials and is often referred to as the 'cellulosic fire curve'. For offshore platforms, FPSO's etc. fire divisions are sometimes required to be resistant to hydrocarbon fuel fires.

Hydrocarbon fire curves are used for fire testing these H-Class, Fire Divisions. The hydrocarbon fire temperature /time curve is significantly more severe in rate of temperature rise and final temperature achieved than the cellulosic fire curve used in the IMO 2010 FTP code. Hydrocarbon fire temperature/time curves are specified in several regulations and various fire test standards. The UK Dept. of Energy, Norwegian Petroleum Directorate, EN 1363-2:1999, ISO 834-3, ASTM 1529 and UL 1709 include definitions of hydrocarbon temperature/time fire curves.

For H-Class fire divisions the fire test is carried out in accordance with the IMO FTP code with the exception that the hydrocarbon fire temperature/time curve is used to heat the furnace instead of the cellulosic fire curve. The commonly accepted classification rules for the division are also different as shown below.

Classification of H-Class Divisions

Class	Integrity (minutes)	Insulation (minutes)
H0	120	0
H60	120	60
H120	120	120

The average and maximum temperature rise (140°C/180 °C) limits specified for A-Class divisions are applied also to H-Class divisions.

Requirements for use of fire divisions

The performance during fire testing of fire divisions is dealt with in the IMO FTP code. The IMO SOLAS II-2 regulations specify where fire divisions are required on a ship and what class of fire division should be used between various spaces based

on the type of space (and likely fire risk). Tables are given showing the classes of fire division required for separating adjacent spaces. Other IMO regulations are also important, notably the IMO 2000 High Speed Craft code which introduces additional fire division classes for use especially on high-speed craft.

Individual Classification Societies (e.g. DNV, RINA) or National Administrations (e.g. the UK MCA) may publish their own rules dealing with fire insulation on vessels especially those intended for special use such as yachts. For offshore platforms, SOLAS regulations do not apply and different procedures are used. These may use Class Society Rules, National Administration Regulations or, more commonly, safety case evaluations. Even so, the A and B-Class divisions are also used in offshore structures along with the H-Class. IMO SOLAS and HSC code regulations define levels of fire separation required between spaces. In SOLAS, these will be A or B-Class divisions with designation as shown in the table on Page 102 (e.g. A0, B15 etc). For high speed craft, the term 'Fire Resisting Division' is used. These have similar, but not identical, performance requirements to A and B-Class divisions.

SOLAS regulations also define a C-Class bulkhead or deck. These are made from non-combustible material but have no requirement to be a fire division, i.e. they do not provide fire separation between spaces. Complying with C-Class requirements will require fire insulation in some cases. This is explained later in this section.

All A and B-Class divisions are required to be manufactured from non-combustible materials. IMO 2010 FTP Part 1 specifies the fire test method and performance requirements for this. SOLAS II-2 Chapter F introduces Alternative Design and Arrangements where the prescriptive rules of SOLAS need not be followed under certain circumstances. The rules allow the use of novel construction materials such as FRP (fibre reinforced plastic) composite materials which would normally be prohibited by SOLAS as they are not non-combustible.

Guide to the specification and performance requirements of fire divisions used in marine and offshore

Fire testing of fire divisions

Fire testing of fire divisions

Fire divisions are tested using fire test furnaces. The fire division is fitted into a restraint frame which is then fixed as either a wall (bulkhead) or roof (deck/floor) on a fire test furnace. The furnace is heated in accordance with a temperature/time fire curve relationship. The IMO FTP code specifies the temperature/time relationship used for A and B-Class divisions. This is based on the combustion of cellulosic materials and is often referred to as the 'cellulosic' fire curve.

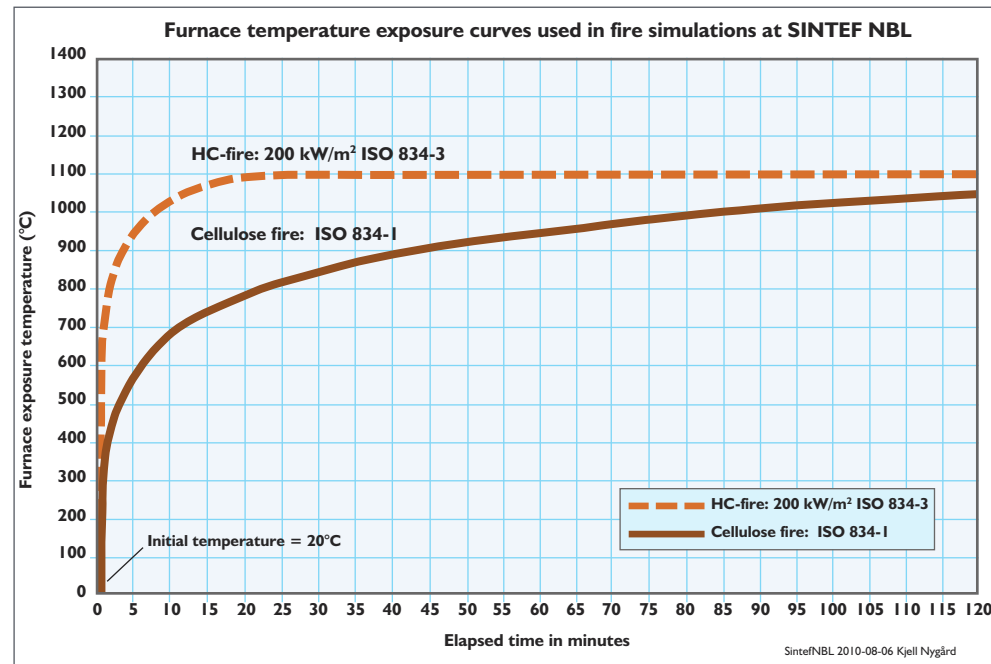

Above: Graph showing the differences between the IMO FTP code temperature / time curve used for A and B-Class fire tests and the hydrocarbon temperature / time curve used for H-Class division fire testing.

Steel bulkhead fire test

This photograph shows a vertical steel bulkhead fire test in progress and the thermocouples used on the unexposed face to measure temperature rises for the 'Insulation' requirement of the fire test. Thermocouples 1 to 5 are used to measure the average temperature rise, thermocouples 6 and 7 are additional thermocouples used to measure the maximum temperature rise over the stiffener angles on the bulkhead ; they are not included in the calculation of the average temperature rise.



For an A-Class bulkhead or deck, the average rise of thermocouples 1 to 5 must not exceed 140°C. None of the 7 thermocouples used must record a temperature rise of more than 180°C (see table on page 102 for temperature limits for B-Class divisions).

The insulation in this case is facing the fire. This is known as 'restricted' application. Normally the steel bulkhead would face the fire with the insulation on the unexposed face. This 'general' or 'unrestricted' steel bulkhead application is a more severe fire test and the insulation can then be fitted either side of the bulkhead in practice. The restricted application is limited only to those applications where the fire risk is always facing the insulated side of the bulkhead.

Aluminium or FRP composite bulkheads and decks require special arrangements of insulation. Those are explained in more detail further in this section.

Guide to the specification and performance requirements of fire divisions used in marine and offshore

Special considerations for fire divisions

Fire divisions manufactured from aluminium

Aluminium is a non-combustible material but has lower strength at high-temperature than steel. SOLAS II-2 regulations require A-Class aluminium fire resisting bulkheads to be insulated on both faces so that the temperature of the bulkhead does not rise above a level where stability may be lost leading to loss of integrity of the fire division.

The IMO 2010 FP code requires an additional temperature rise criterion to be met for all aluminium divisions when fire tested. The 'core' of the division must not rise by more than 200°C. According to MSC/I 120 C.11.3.1. If an aluminium deck is tested with insulation installed below the deck, then the result will apply to decks, which are bare on the top. Aluminium decks may not be provided with deck coverings on the top unless tested with the deck covering to verify that the 200°C temperature of the aluminium is not exceeded.

The core temperature is measured during the fire test using 5 thermocouples attached into the bulkhead or deck plate underneath the insulation lining exposed to the fire. The 200°C core temperature rise limit must not be exceeded within 60 minutes for all A-Class divisions and within 30 minutes for all B-Class divisions - i.e. the same time period as required for the integrity criterion of the fire test.

'A0' rated Aluminium fire divisions

An A0 division, like all A-Class divisions, must provide 60 minutes integrity. The integrity will be lost if stability is also lost which means that an A0 fire division must satisfy the core temperature rise requirement of 200°C for 60 minutes.

Fire insulation is required to be used on A0 aluminium fire divisions to ensure the 200°C core temperature rise is not exceeded. The amount of fire insulation required to be installed to meet this requirement is usually about the same as that required for an A30 aluminium division.

Fire divisions used in vessels built to the High-Speed Craft code

IMO 2010 FTP code Part 11 describes the fire testing method to be used for fire divisions used in vessels built in accordance with the IMO High Speed Craft

(HSC) Code. The HSC code differs from the SOLAS regulations in definition and requirements of fire divisions.

Fire divisions used in high-speed craft do not have to be constructed from non-combustible materials. The use of 'fire restricting materials' is allowed instead. A 'fire restricting' material is a material that can satisfy the 'room-corner' fire test procedure specified in IMO 2010 FTP Code Part 10.

Fire divisions used for vessels built in accordance with the IMO HSC code are classed as 'Fire Resisting Divisions' (FRD). These have different terminology and performance requirements to A and B-Class divisions (as shown in the table below). Bulkheads may also be (and in practice often are) of 'restricted' application i.e. the fire risk always faces the insulated side.

Table 1: Performance requirements for HSC fire resisting divisions

Class	Integrity (minutes)	Insulation (minutes)
60 Minute High Speed Craft FRD	60	60
30 Minute High Speed Craft FRD	30	30

Table 2: Equivalent 'HSC FRD' divisions to SOLAS fire divisions

SOLAS II-2 fire division class	IMO 2000 High Speed Craft Code equivalent to SOLAS II-2 fire division class	IMO fire testing methods used
A-Class	60 minute fire resisting division	IMO 2010 FTP code part 11
B-Class	30 minute fire resisting division	IMO 2010 FTP code part 11
C-Class	Fire restricting material	IMO 2010 FTP code part 10

Guide to the specification and performance requirements of fire divisions used in marine and offshore

Special considerations for fire divisions

HSC code fire resisting divisions for are classed either as 'non-loadbearing' or 'loadbearing' and the fire testing procedures differ.

- Non-loadbearing divisions are tested following the requirements for B-Class divisions of IMO 2010 FTP code Part 3
- Loadbearing divisions constructed from metallic cores are tested following the requirements for A-Class divisions of IMO 2010 FTP Code Part 3. Aluminium cores have the same core temperature rise limit as the equivalent A or B-Class division when tested to IMO 2010 FTP code Part 3.
- Loadbearing divisions constructed from non-metallic materials are tested in accordance with requirements for B-Class divisions but with the addition of an applied static load during the fire test. The load values differ for bulkheads and decks and are specified in IMO 201 FTP code Part 1.1. In this test values for maximum deflection and/or rate of deflection for the bulkhead or deck are specified.

The loads applied are:

- 7kN per m of width on bulkhead
- 3.5kN per m² of deck area

Performance requirements for load-bearing ability are:

Bulkheads

1. limiting axial contraction of $h/100$ mm; and
2. limiting rate of axial contraction of $3h/1,000$ mm/min,

where:

h = the initial height (mm);

Decks

1. limiting deflecting of $(L)2/400$ d mm; and
2. limiting rate of deflection of $(L)2/9,000$ d mm/min,

where:

L = the clear span of the specimen (mm); and

d = the distance from the extreme fibre of the design compression zone to the extreme fibre of the design tension zone of the structural section (mm).

The rate of deflection criteria of decks is not applied until a deflection of $L/30$ has been exceeded.

Comparing A30 and 30-minute HSC aluminium FRD divisions

Comparing an A30 division to a 30 minute High Speed Craft FRD, it is important to realise that the A30 division requires 60 minutes Integrity whereas the 30 minute HSC FRD requires only 30 minutes. A 30 minute FRD division built from aluminium could require less fire insulation than an A30 division as the insulation of the core is required for 30, not 60, minutes.

Fire divisions manufactured from non-metallic materials - FRP composites

Yachts and High Speed craft are often constructed using lightweight FRP materials to minimise superstructure weight or (in the case of yachts) for visual design reasons. Special consideration is required for fire divisions manufactured using these materials and this can be a complex area due to the variety of different approaches taken.

As A and B-Class divisions must be constructed from non-combustible materials, a fire division constructed from FRP composite materials cannot be classified as A or B-Class. C-Class divisions cannot be constructed using FRP composite materials as they are required also to be non-combustible. To classify a fire division for use on ships, the equivalent High Speed Craft code divisions as shown in table 2 (page 105) can be used to ascertain equivalent performance.

Guide to the specification and performance requirements of fire divisions used in marine and offshore

Special considerations for fire divisions

The effect of the fire test performance on insulation requirements for FRP composite structures should be understood because insulation thicknesses are not governed by the unexposed face temperature rise requirements as with metallic divisions.

FRP materials have much less strength at temperature than metallic divisions. A FRP composite division will require much more insulation to ensure its temperature is maintained below the point at which it would lose its integrity.

This is especially important for any 'load-bearing division' as defined by the deflection requirements given in the IMO 2010 FTP code Part 11 test procedure. The point of failure of a FRP composite structure in a fire test is more likely to be due to collapse and loss of integrity rather than unexposed face insulation failure.

Fire testing of FRP composites should take account of the strength of the specific structure design, as this can vary significantly due to different fibre materials, resin types and (in sandwich panel types of construction) core materials used.

To simplify the number of fire tests required, one approach is to identify a weak, 'worse-case' structure design and use this as the test specimen tested. The insulation system could then be applied to any design evaluated to be stronger.

The effect of changing the FRP structure materials can be very significant. Fire tests sponsored by Morgan Advanced Materials Thermal Ceramics have demonstrated that using stronger FRP composite materials can almost double the duration of fire resistance achievable from a bulkhead even with less insulation than used in fire tests on a weaker structure.

SOLAS II-2 Part F allows alternative materials other than metal to be used for construction of ships. There is a need to demonstrate equivalent performance to steel. In terms of required fire performance, table 2 on page 105 can be used as a guide.

The IMO 2000 HSC code also allows non-metallic materials of construction for high speed craft, table 1 and table 2 on page 105 detail the terminology and requirements.

With FRP composites, the combustible structure can be rendered functionally equivalent to a C-Class division through the use of insulation of sufficient thickness to meet the requirements of IMO 2010 FTP code part 10, the 'room corner test'.

A thin layer of FireMaster Marine Plus blanket, applied over the structure is sufficient to meet this need as illustrated in table 3 on page 108.



Room corner test in process showing the burner placed in the corner of the room

Guide to the specification and performance requirements of fire divisions used in marine and offshore

Special considerations for fire divisions

Table 3: Performance of FireMaster Marine Plus blanket in room corner test

Required performance in IMO room corner test	Results using 25mm x 64kg/m ³ Marine Plus	Results using 20mm x 48kg/m ³ Marine Plus
Average Heat Release < 100kW	13kW	33kW
Max Heat Release < 500kW	90kW	113kW
Average Smoke Production Rate < 1.4m ² /s	0.2m ² /sec	0.7m ² /s
Max Smoke Production Rate < 8.3m ² /s	0.5m ² /sec	2.5m ² /s
Flaming Droplets None outside the area 1.2m from the corner where the flame is located	None	None

Classification of non-metallic fire divisions for yachts

For yachts, there are several different regulations issued by National Maritime Bodies or Classification Societies. Examples are the MCA LY3 Large Commercial Yacht Code, RINA 'Rules for classification of yachts designed for commercial use'.

These regulations often have different requirements than the IMO FTP Code for assessing the performance of fire divisions made from non-metallic materials. The most significant difference is the requirement for insulation on the fire-exposed side to maintain the surface of the composite structure below the Heat Distortion Temperature (HDT) of the resin used to bond the laminated panel fibres together. It is assumed that integrity of the division will be maintained as the division will not collapse if the HDT is not exceeded. Fire testing in such cases is not carried out in accordance with the IMO 2010 FTP code procedures. Notably, much smaller (often very small) sized test specimens than specified in the

IMO 2010 FTP code are used. No load is applied to the specimen and therefore significant deflection of the test specimen does not occur reducing the potential for testing the insulation system joint integrity.

When assessing the required performance of fire rated FRP composite divisions in yachts care should be taken to understand the degree of fire resisting performance that is actually required. For an 'A30' equivalent fire division, 60 minutes integrity is required because all A-Class divisions provide 60 minutes integrity. Insulation performance must be sufficient to ensure collapse does not occur for 60, not 30 minutes. If the division is only required to provide 30 minutes integrity this should be explicitly stated. It should not be described as an 'A30 equivalent' division.

Hydrocarbon fire protection of steel divisions on offshore structures - insulation against fire

According to MSC/Circ. 1120 interpretation of SOLAS II-2 C11.3.1, a load-bearing division is 'a deck or bulkhead including stiffeners, pillars, stanchions and other structural members which, if eliminated, would adversely affect the designated structural strength of the ship.' A-Class steel bulkheads or decks of the same thickness and stiffening details as those specified in IMO 2010 FTP code part 3 Chapter 2 are considered to be load-bearing. Other thinner or differently-stiffened or shaped bulkheads or decks are considered to be non load-bearing.

A-Class steel bulkheads and decks considered to be load-bearing can be used facing the fire risk without insulation applied on the fire-exposed face.

For load-bearing H-Class bulkheads, insulation is required on the fire side to ensure the structural core temperature is maintained below 400°C. Many designs of offshore modules (living quarters, process equipment modules etc.) use non-loadbearing bulkheads attached to a load-bearing support structure. These can be insulated on the non-fire side. Insulation is not required on the fire exposed side.

For decks, insulation is always applied on the fire exposed side; floating floors are fire tested with the non-insulated steel side of the deck facing the fire. Difficulty often occurs when fire insulation is fitted to the underside of a roof with a hydrocarbon

Guide to the specification and performance requirements of fire divisions used in marine and offshore

Special considerations for fire divisions

fire risk on the top (non-insulated) side of the roof. Fire testing of such designs is not covered by the IMO 2010 FTP code and is extremely difficult to carry out due to the general lack of fire testing laboratories with furnaces capable of testing a fire above a roof with insulation fitted below the roof. In recognition of this, a case-specific review of the fire scenario is usually made and the use of the corresponding 'general' case (unrestricted, steel side facing fire) bulkhead insulation system may be permitted subject to classification society agreement.

Type approval certification of fire divisions

Once successfully fire tested in an approved fire test laboratory, fire divisions can be type approved through any IACS classification society. The type approval certificate usually has fixed validity (typically 4 to 5 years depending on Classification Society) and under the IMO 2010 FTP code may be renewed for a maximum of 15 years before re-testing is required. Systems with an existing type approval issued before the introduction of the IMO 2010 FTP code may also be renewed for 15 years before new fire testing in accordance with the IMO 2010 FTP code is required.

For a new type approval to be issued for a system tested before the introduction of the IMO 2010 FTP code, the fire test must be no older than 5 years. H-Class fire divisions are not referenced within the IMO 2010 FTP code so are not technically subject to the same limitation on validity of the fire test. However, most class societies will apply the same limits for validity for H-Class division type approvals.

EU marine equipment directive approvals

The EU MED applies to all ships whose safety certification is issued by or on behalf of Member States of the European Union. Annex A1/3 of the directive lists fire protection items that may be approved under the directive. Testing requirements are those specified in the IMO FTP code.

Two different approval types are typically issued for fire divisions; a Module B approval and a Module D approval. Module B is the approval of the fire division design and Module D is the manufacturing quality approval for the manufacturing plant. Approvals may be issued by any EU MED 'Notified Body', these include major classification societies. Approved products are marked with the 'Wheelmark' logo to indicate conformity with the directive. In the case of A and B-Class fire divisions where an insulation material is fitted onto a structure on board a ship in accordance with a specified design, the 'Wheelmark' mark of conformity is normally applied to the fire insulation packaging indicating the conformity of the product as a non-combustible material.

The format of the Mark of Conformity or 'Wheelmark' is specified in Annex D of the MED. It is the sign that the product is declared by its manufacturer to conform to type and therefore be in compliance with SOLAS (or other Convention) performance requirements.

Manufacturers are required to issue a Declaration of Conformity (DoC) for products indicating the Annex Number complied with and other details. H-Class divisions are not referenced in Annex A1/3 of the EU MED and therefore cannot be approved under the directive. US Coastguard approval numbers are automatically issued for any fire division with an EU MED Module B and Module D approval under the Mutual Recognition Agreement (MRA) between the USA and EU. The exception to this are the FRD divisions used for High-Speed Craft, which are not currently covered by scope the MRA. These require separate application to USCG for type approval.



FIREMASTER[®]

Morgan Advanced Materials Fire Protection product range

Morgan Advanced Materials Fire Protection product range

Morgan Advanced Materials FireMaster® products are used all over the world to protect people and structures against fire.

The wide variety of FireMaster® Fire Protection Systems are comprehensively certified and extensively tested to meet national and international standards, offering our customers the security of global proven fire performance in various market sectors:

- **Commercial buildings, hotels, sports stadia and airport terminals**
- **Industrial plants**
- **Petrochemical plants**
- **Offshore platforms and FPSO's**
- **Cruise ships, military vessels, mega yachts and fast ferries**
- **Tunnels and underground construction**

Systems are tested to many international standards and have approvals valid worldwide for cellulosic, hydrocarbon and jet fire protection.

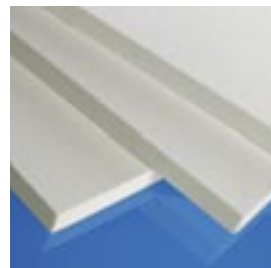

Products

FireMaster Marine Plus blanket: The new ultra-lightweight fire insulation from Morgan Advanced Materials designed for weight sensitive applications. Weight savings of 20 to 30% are typical compared to standard FireMaster blanket and alternative lightweight solutions. Systems are available for composite, steel and aluminium structures.

FireMaster Marine Plus faced blanket: FireMaster Marine Plus blanket is available with surface coatings of aluminium or glass cloth.

FireMaster Marine Plus water repellent blanket: FireMaster Marine Plus blanket is available with a water repellent treatment through the entire blanket thickness to inhibit water ingress.

FireMaster RES system: A rigid metallic enclosure for jet fire protection of valves, actuators and flanges.

FireMaster cable tray wrap: FireMaster blanket totally encapsulated in aluminium foil. Approved by Factory Mutual for hydrocarbon fire protection of instrument and control cables.

FireMaster board: Three different grades of FireMaster board are available to offer designers a choice of products most suitable to their application. Now includes FireMaster 200 board developed especially for solid core fire doors.

FireMaster expanding felt: Expands to 3 times its original thickness to seal gaps, joints and penetration seals.

FireMaster FireFelt: Compressible felt suitable for applications where very low weight and good resilience are required.

FireMaster FireBarrier 135: Sprayed refractory cement solutions for fire protection of steelwork, vessels and floating floors in ships.

FireMaster FlexiJet: Flexible jacket system for fire protection of process equipment and structures.

WDS microporous products: Highest efficiency in thermal insulation available in rigid and flexible product forms. For use where space saving is important or for exceptional low weight.



FIREMASTER[®]

For all enquiries, please contact our specialist regional sales and manufacturing sites.

Europe

Morgan Thermal Ceramics UK Ltd.
Tebay Road, Bromborough
Wirral, Merseyside. CH62 3PH
United Kingdom

T: +44 (0)151 334 4030

F: +44 (0)151 334 1684

E: marketing.tc@morganplc.com

North America

Morgan Thermal Ceramics Inc.
2102 Old Savannah Road
Augusta, Georgia 30906
USA

T: +1 (706) 796 4200

E: marketing.tc@morganplc.com

South America

Morganite Brazil LTDA.
Rua Darcy Pereira 83
Distrito Industrial de Santa Cruz
23565-190 Rio de Janeiro-RJ, Brazil

T: +55 (21) 3305 7400

F: +55(21) 2418 1205

E: marketing.tc@morganplc.com

Asia

Morgan Ceramics Asia Pte Ltd.
150 Kampong Ampat
#05-06A KA Centre
Singapore 368324

T: +65 6595 0000

F: +65 6595 0005

E: marketing.tc@morganplc.com